



THE ATEX RANGE - safe & competent  
Lifting experience

[www.cmco.eu](http://www.cmco.eu)

## Why explosion protection?

Explosion protection for electrical and mechanical machinery is an important precautionary measure to ensure the safety of persons and all kinds of production, storage and distribution systems, when explosive mixtures of combustible gases, dusts and air may occur.

## What does explosion protection achieve?

Explosion protection can mean to generally prevent the occurrence of an explosive mixture. Explosion protection can also be achieved by eliminating potential ignition sources in advance, e.g. high temperatures and sparking by designing components accordingly and by permanent monitoring of operation, or by using a flame-proof enclosure for the source of ignition to protect the surrounding area against possible effects of an internal explosion.

## Examples of explosion hazards in various industries:

### Chemical industry

In the chemical industry, combustible gases, liquids and solids are converted and processed in various procedures. Explosive mixtures may be created during these processes.

### Waste disposal sites

At waste disposal sites, combustible gases may form. Comprehensive technical measures are required to prevent their uncontrolled escaping and possible ignition.

### Energy production companies

Coal dust, which may form explosive dust/air mixtures, may occur during production, breaking and drying from coal lumps which themselves are not explosive with air.

### Waste management companies

The fermentation gases released during treatment of waste water in waste water treatment plants may form explosive gas/air mixtures.

### Gas suppliers

If natural gas escapes through leakages or similar, explosive gas/air mixtures may be created.

### Metal processing companies

During the production of formed metal parts, explosive metal dusts may occur during surface treatment (grinding). This applies in particular to light metals. These metal dusts may cause an explosion risk in separators.

### Wood-processing companies

When processing wood workpieces, wood dust occurs, which may form explosive dust/air mixtures in filters or silos for example.

### Paint shops

Overspray, which may occur during painting of surfaces using spray guns as well as any released solvent vapours, may form an explosive atmosphere with air.

### Agriculture

Some agricultural facilities operate systems for the production of biogas. If biogas escapes as a consequence of leakages, for example, explosive biogas/air mixtures may form.

### Food and feeding-stuffs industry

During the transportation and storage of grain, sugar, etc. explosive dusts may occur. When these are evacuated and separated using filters, an explosive atmosphere may occur in the filter.

### Pharmaceutical industry

In pharmaceutical production, alcohols are frequently used as solvents. Furthermore, active and auxiliary substances with a dust explosion hazard may also be used.

### Refineries

The hydrocarbons processed in refineries are all combustible and, depending on their flash point, are capable of causing an explosive atmosphere even at ambient temperatures.

### Recycling companies

When processing recycling waste, explosion hazards may be caused by cans which are not completely empty or other containers with combustible gases and/or liquids; explosion hazards may also be caused by paper or plastic dust.

## Cooperation of parties involved

### Obligations of user, installer and manufacturer

Close cooperation of all parties involved is essential for the safety in potentially explosive areas.

The user is responsible for the safety of the installation. He has to assess possible explosion hazards and assign zones accordingly.

In addition, he is also responsible for ensuring that the equipment is installed in accordance with regulations and is tested before it is put into service for the first time. The equipment must be kept in appropriate condition by regular inspections and maintenance.

The installer must observe the relevant installation requirements and select and install the equipment correctly for its intended use.

Manufacturers of explosion-proof equipment must ensure that each device manufactured complies with the type-tested design.

### Legal basis

The acronym ATEX is the abbreviation of the French term "Atmosphères explosibles", which means explosive atmospheres. This designation is currently still used as a synonym for these two directives of the European Union: 94/9/EC (ATEX 95, previously ATEX 100a) and 99/92/EC (ATEX 137, previously ATEX 118a).

Directive 94/9/EC is primarily intended for manufacturers of explosion-proof equipment.

Directive 99/92/EC is primarily intended for users of installations with a potentially explosive atmosphere.

### Risk assessment

For taking efficient measures in areas with an explosion hazard, a risk assessment in accordance with national health and safety regulations taking into account national industrial safety acts as well as hazardous substances ordinances must be carried out first. If this risk assessment shows that the formation of explosive atmospheres is not safely prevented, the likelihood that explosive atmospheres will occur based on their frequency and persistence, the likelihood that ignition sources will be present and become active and effective and the scale of the anticipated effects of explosions must be determined. The results of the risk assessment must be recorded in the form of an **explosion protection document**.

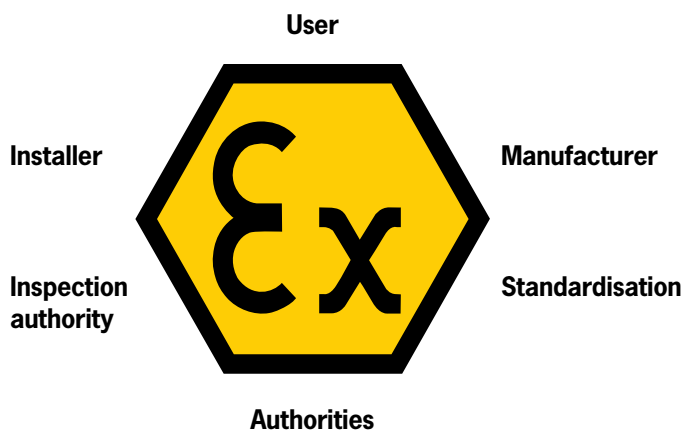

## Categories and zones

### Requirements from the ATEX directives to be fulfilled by manufacturer and user

Essential requirements to be fulfilled by the manufacturer according to 94/9/EC	Essential requirements to be fulfilled by the user according to 99/92/EC
Definition of the area for the use of equipment, specifications of equipment group II/category	Definition of zones in an installation; selection of the appropriate equipment
The equipment must comply with the essential safety and health requirements or the relevant standards	Compliance with the relevant requirements for installation, putting into service and maintenance
Category 1 Category 2 Category 3	Zone 0/20 Zone 1/21 Zone 2/22
Performance of a risk/ignition source assessment for the relevant equipment	Performance of a hazard analysis for the operating area; need for coordination
Compilation of a declaration of conformity	Compilation of an explosion protection document
Appropriate quality assurance	Regular updating

### Technical basis

In Directive 94/9/EC, equipment for areas with an explosion hazard is assigned to groups, categories and temperature classes. This is necessary as the requirements for equipment need not be the same for every application and for every hazard classification.

#### Equipment group I (mines, firedamp and combustible dusts)

Category M1	Category M2
Very high level of protection: Equipment must feature integrated explosion protection measures	High level of protection: Protection measures must ensure the required level of safety during normal operation also under arduous conditions and in particular heavy handling and under changing ambient conditions
The equipment must continue to operate in an explosive atmosphere even in the event of rare faults	It must be possible to switch off the equipment if an explosive atmosphere occurs

#### Equipment group II (explosive atmospheres caused by mixtures of gas/air or dust/air, vapours or mists)

Category	Zone		Equipment safety	Explosive atmosphere
	G [Gas]	D [Dust]		
1	0	20	Equipment which ensures a very high level of safety.  In the event of rare equipment faults.	Intended for use in areas in which explosive atmospheres caused by mixtures of air and gases, vapours or mists or by air/dust mixtures are present <b>continuously, for long periods or frequently.</b>
2	1	21	Equipment which ensures a high level of safety.  If equipment faults are to be expected.	Intended for use in areas in which explosive atmospheres caused by mixtures of air and gases, vapours or mists or by air/dust mixtures are likely <b>to occur occasionally.</b>
3	2	22	Equipment which ensures a normal level of safety.  For normal operation	Intended for use in areas in which explosive atmospheres caused by gases, vapours or mists or whirled up dust are unlikely to occur or, if they do occur, are likely to do so only <b>infrequently and for a short period.</b>

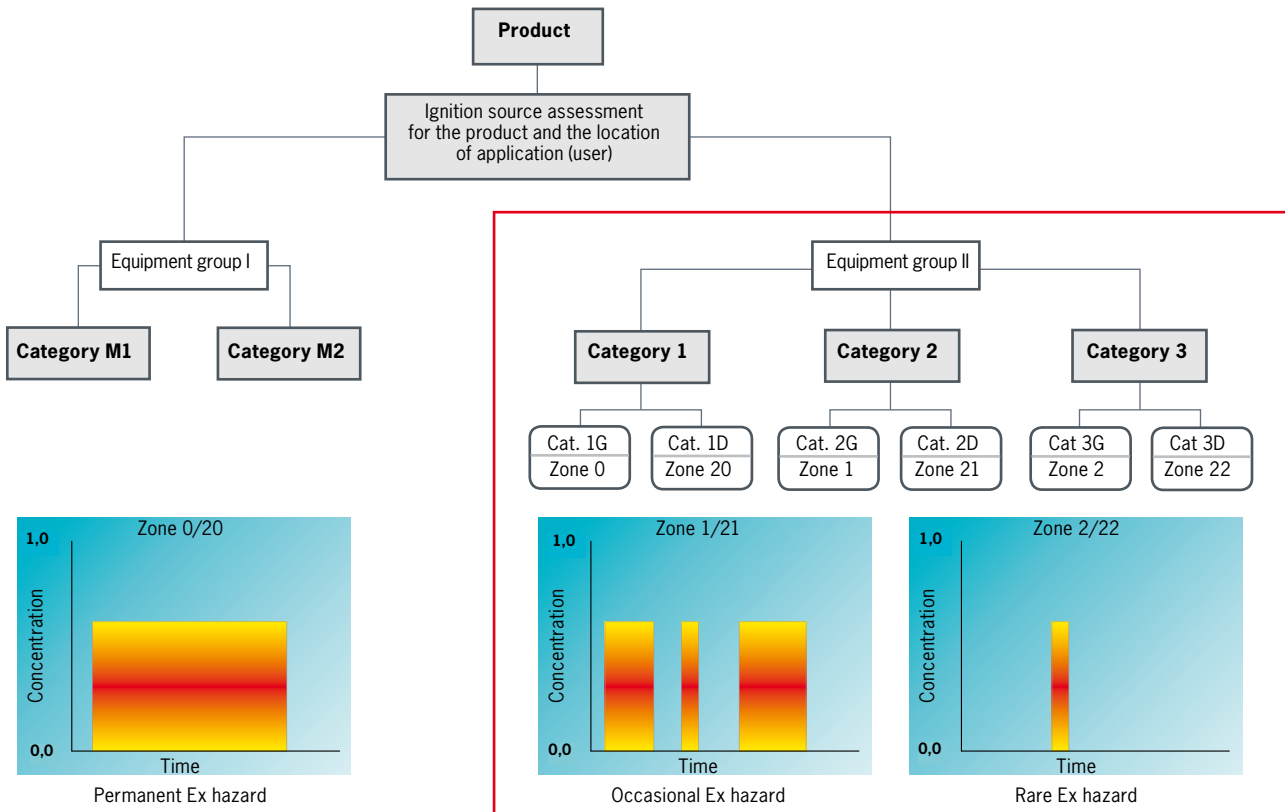

## Preconditions for an explosion

Explosive atmospheres may occur wherever combustible gases, vapours, mists or dusts can form. These are mixtures which produce a chemical reaction when they meet the oxygen in the air; this reaction may trigger an explosion, even if only an extremely small spark occurs.

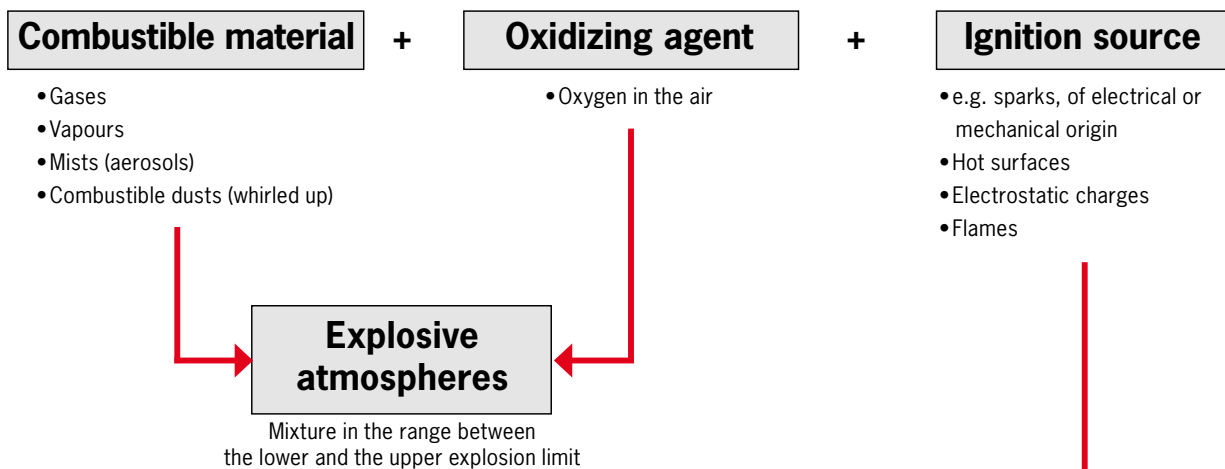

## Explosion limits

In order to prevent an explosion, the relevant key data of combustible substances must be observed.

Mixtures can only cause an explosive ignition within a specific range.

This is defined by the lower and the upper explosion limit.

## Explosion limits of selected gases and vapours

Substance designation	Explosion limits in air	
	Lower volumes %	Upper volumes %
Aceton	2,5	13,0
Benzol	1,2	8,0
Methane	5,0	15,0
City gas	4,0	30,0
Hydrogen	4,0	75,6

## Minimum ignition energy

The minimum ignition energy is an explosion related parameter.

It describes the ignition sensitivity compared to the discharge of static electricity.

## Examples for minimum ignition energy

Substance designation	Min. ignition energy
Mustard seed oil	3,8 mJ
Methane	0,29 mJ
Ethylene	0,082 mJ
Hydrogen	0,017 mJ

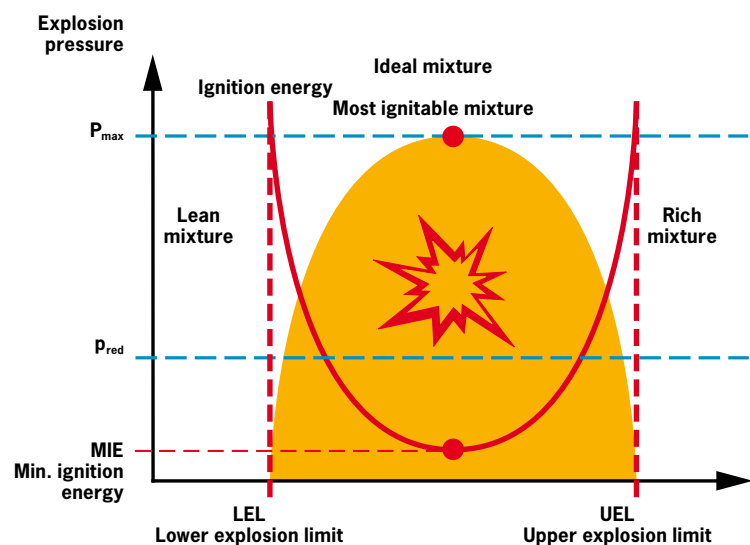

Primary explosion protection	Secondary explosion protection	Tertiary explosion protection
<b>Prevent the formation of potentially explosive atmospheres</b>	<b>Prevent the ignition of potentially explosive atmospheres</b>	<b>Restrict the effects of an explosion</b>
Inerting*	Open flames	Explosion-pressure resistant design
Limit concentration under the lower explosion limit	Hot gases	Pressure compensation surfaces for buildings
	Hot surfaces	Explosion suppression
	Elektrical sparks	
	Atmospheric discharge	

### \*Inerting substances

Inerting substances means their transformation or processing into slow-reacting (inert) substances. Inert substances are, for example, inert gases, glass and porcelain. In refuse dump systems, inerting is used, for example, to render hazardous waste substances harmless.

Substances containing heavy metal, which are radioactive or otherwise detrimental, are, for example, often glazed in order to make it possible to finally dispose of them.

### Inerting rooms

Inerting rooms means to displace the oxygen contents in the air or potentially reactive or explosive gases or gas mixtures in rooms by adding inert gases or vapours. When inerting as a protection against fire and explosion (industry example: chemicals storage or production facilities), the oxygen contents in the air are displaced by adding inert gas (e.g. argon, nitrogen, carbon dioxide) in order to prevent an explosive atmosphere. In fire protection, this is also called "active fire prevention by permanent inerting".

## Temperature classes

The ignition temperature is the lowest temperature of a heated surface at which the gas/air or vapour/air mixture ignites. In other words, it represents the lowest temperature value at which a hot surface is capable of igniting the corresponding explosive atmosphere.

Thus the highest surface temperature of any equipment must always be less than the ignition temperature of the gas/air or vapour/air mixture.

### Temperature classes

Temperature classes	Permissible max. surface temperature of the equipment	Ignition temperature range of the mixtures
T1	450°C	>450°C
T2	300°C	>300... ≤ 450°C
T3	200°C	>200... ≤ 300°C
T4	135°C	>135... ≤ 200°C
T5	100°C	>100... ≤ 135°C
T6	85°C	>85... ≤ 100°C

## Explosion groups

Equipment of group II, for appropriate use in explosive gas atmospheres may also be classified by the type of explosive area.

### Explosion groups

Explosion group of the explosive atmosphere	Equipment with marking of the explosion group which may be used in these atmospheres
IIA	IIA, IIB, IIC
IIB	IIA, IIB
IIC	IIC

This classification is based on the Maximum Experimental Safe Gap (MESG) and the Minimum Ignition Current (MIC) of the gas mixture (see IEC 60079-12) or the explosion groups can also be used for classification of the equipment based on their inflammability.

### Explosion groups and maximum experimental safe gap

Explosion group	Maximum experimental safe gap
IIA	> 0,9 mm
IIB	≤ 0,9 - ≥ 0,5 mm
IIC	< 0,5 mm





**Classification of combustible gases, vapours and mists**

Explosion groups and temperature classes of some gases and vapours (selection)

**Classification of combustible gases, vapours, mists**

Ex group	Temperature classes					
	T1	T2	T3	T4	T5	T6
	Ignition temperature range of the mixtures					
	> 450°C	> 300 ≤ 450°C	> 200 ≤ 300°C	> 135 ≤ 200°C	> 100 ≤ 135°C	> 85 ≤ 100°C
	Permissible max. surface temperature of the equipment					
450°C	300°C	200°C	135°C	100°C	85°C	
<b>IIA</b>	Acetone	Ethanol	Petrol (general)	Acetaldehyde		
	Ammonium	i-Amyl acetate	Diesel fuels			
	Benzene (pure)	n-Butane	Aircraft fuels			
	Acetic acid	n-Butanol	Fuel oil DIN 51603			
	Ethane	Cyclohexan	n-Hexane			
	Ethyl acetate	Acetic anhydride				
	Ethyl chloride					
	Carbon monoxide					
	Methane					
	Methanol					
	Methyl chloride					
	Naphthalene					
	Phenol					
	Propane					
Toluene						
<b>IIB</b>	City gas	Ethylene	Ethylene glycol	Ethyl ether		
		Ethylene oxide	Hydrogen sulfide			
<b>IIC</b>	Hydrogen	Acetylene				Carbon disulphide



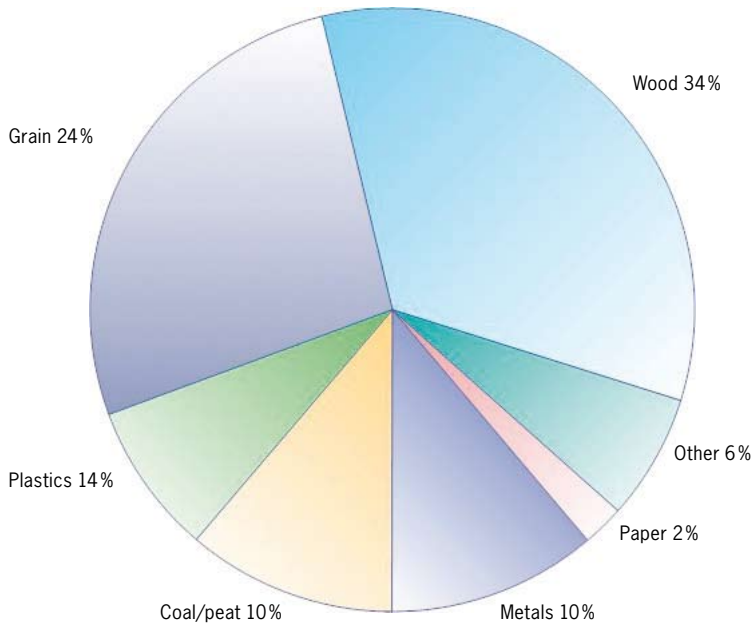

**Permissible equipment IP code by zones and type of dust**

Zone 20	Zone 21 Zone 22 electrically conductive dust	Zone 22
IP6X	IP6X	IP5X
Marking II 1 D	Marking II 2 D	Marking II 3 D

**Dust-explosion protection**

Today, in many industries, powder or dust-like products are processed or are by-products of the production process.

The vast majority of all dust-like substances pose a danger of fire or – under certain conditions – even explosion. A dust layer of only 1 mm in a closed room is already sufficient to trigger an explosion when the dust is whirled up and ignited.

The graphic shows that many different industries are affected by the hazard of dust, ranging from the food-stuffs and wood-processing industries, paper and plastic material production to the pharmaceutical industry. Compared with gas explosions, dust explosions have a different process of propagation which may in some cases be much more devastating. If a gas/air mixture is ignited, the pressure of the resulting explosion causes the gas cloud to dissipate rapidly and thus finally dilutes the gas/air mixture to a concentration lower than that necessary for further combustion. If no further gas is added, the explosion is over after several milliseconds.

With combustible dusts it is different: If, for example, a draft of air whirled up a layer of dust, the dust, together with oxygen, forms a combustible dust/air mixture. If this mixture is ignited by an ignition source, an explosion is triggered.

The resulting blast wave whirled up further dust layers, which are in turn also ignited. This process continues, and, under adverse conditions, “chain reactions” such as these sweep through entire buildings or facilities and destroy them.

As is the case with gases, there are various ignition sources for dusts, such as sparks generated by electrical or mechanical processes, electric arcs, openflames, electrostatic discharges, electromagnetic waves and others.

**Definitions in dust explosion protection**

Term	Definition	Remarks
Explosive dust atmosphere	Mixture with air, under atmospheric conditions, of combustible substances in the form of dust or fibres in which, after ignition, combustion spreads throughout the entire unconsumed mixture. (DIN EN 50281-1-1,3.4)	The condition is that the process ends only after one reactant has been entirely consumed.
Atmospheric condition	Range of pressure between 0.8 and 1.1 bar Temperature range between -20° C and +60° C	
Hazardous explosive atmospheres	Explosive atmosphere in hazardous amount. The presence of a hazardous explosive atmosphere must be assumed if ignition causes an exothermal reaction that endangers persons, domestic animals and property.	A thickness of a dust layer of less than 1 mm on the floor of a normal room is sufficient to fill it with a hazardous explosive atmosphere.

**Safety characteristics of dusts**

Characteristic	Definition/description	Remarks
Particle size	Dust with a particle size larger than 400 µm is not considered to be ignitable. Dust particles are ignitable when they measure less than 20 µm up to 400 µm.	Due to abrasion, the transportation and processing of coarse dust result in the formation of fine dust.
Explosion limits	For most dust/air mixtures of combustible substances the lower explosion limit is approx. 20... 60 g/m <sup>3</sup> air and the upper explosion limit approx. 2... 6 kg/m <sup>3</sup> air	In this case allocation of particle size, density, humidity as well as the ignition point is decisive.
Maximum explosion pressure	In enclosed containers of simple design, combustible dust can reach explosion pressures of 8... 10 bar.	For light metal dusts the explosion pressure can exceed this value.
Kst value	This is a classification value which expresses the shattering effect of the combustion. Numerically, it is equal to the value of the maximum rate of explosion pressure rise during the explosion of a dust/air mixture in a 1 m <sup>3</sup> vessel.	This value is the basis for calculating explosion pressure relief surfaces.
Moisture	The moisture of a dust is a significant factor for its ignition and explosion behaviour. Currently it is only known that a higher moisture content requires a higher ignition energy and impedes the formation of dust swirls.	
Minimum ignition energy E <sub>min</sub>	Lowest energy of an electrical spark which is sufficient to effect ignition of the critical (most easily ignitable explosive) dust/air mixture under defined framework conditions.	Not every spark is ignitable. The decisive factor is whether sufficient energy is introduced into the dust/air mixture to initiate a self-sustaining combustion of the entire mixture.
Ignition temperature T <sub>ig</sub>	The lowest temperature of a hot inner wall (e. g. furnace) on which the dust/air mixture is ignited after brief contact. The surface temperature must not exceed 2/3 of the ignition temperature in °C of the relevant dust/air mixture, e. g. starch/milk powder/gelatine  Ignition temperature 390 °C x 2/3 = 260 °C max. permissible surface temperature $T_{max} \leq \frac{2}{3} T_{ig}$	
Smouldering temperature T <sub>sm</sub>	The lowest temperature of a hot surface on which ignition occurs in a dust layer with a thickness of 5 mm. On surfaces where a dangerous deposit of ignitable dust is not effectively prevented, the surface temperature must not exceed the ignition temperature reduced by 75 K of the respective dust.  With layer thicknesses over 5 mm, a further reduction of the temperature of the surface is necessary: e. g. wood, grinding dust Ignition temperature 290 °C - 75 °C = 215 °C max. permissible surface temperature $T_{max} \leq T_{sm} - 75K$	The smouldering temperature is usually well below the calculated ignition temperature of a dust cloud. The smouldering temperature decreases almost linearly with an increase in the layer thickness. For the acceptable surface temperatures safety clearances have to be adhered to.



## Explosion characteristics of dusts

Generally applicable values for dust-specific characteristics cannot be specified. The table shows some limit values for selected products:

Examples of explosion characteristics of dusts

Substance	T <sub>ig</sub> [°C]	T <sub>sm</sub> [°C]	ØE <sub>min</sub> [mJ]	min [mJ]
Wood	≥ 410	≥ 200	≥ 100	6
Lignite	≥ 380	≥ 225	–	5
Coal	≥ 500	≥ 240	≥ 1000	13
PVC	≥ 530	≥ 340	≥ 5	< 1
Aluminium	≥ 560	≥ 270	≥ 5	< 1
Sulphur	≥ 240	≥ 250	10	5
Lycopodium	≥ 410	–	–	–

## Marking key

Example		123		II	2	G	Ex	d	T3
---------	---	-----	---	----	---	---	----	---	----

### CE marking

Code number of the notified body

Identification for protection against explosions (ATEX 100a)

Equipment group  
II = Non-mining application

Category  
1 = extremely high safety  
2 = high safety  
3 = normal safety

Ex atmosphere  
G = Gas  
D = Dust

Explosion protection

Protection type  
p = pressurized enclosure  
d = flame-proof enclosure  
e = increased safety  
nA = non-sparking  
i = intrinsic safety  
c = design safety  
b = ignition source monitoring  
k = liquid immersion

Temperature class

Limit temperature  
T1 = max. 450°C  
T2 = max. 300°C  
T3 = max. 200°C  
T4 = max. 135°C  
T5 = max. 100°C  
T6 = max. 85°C

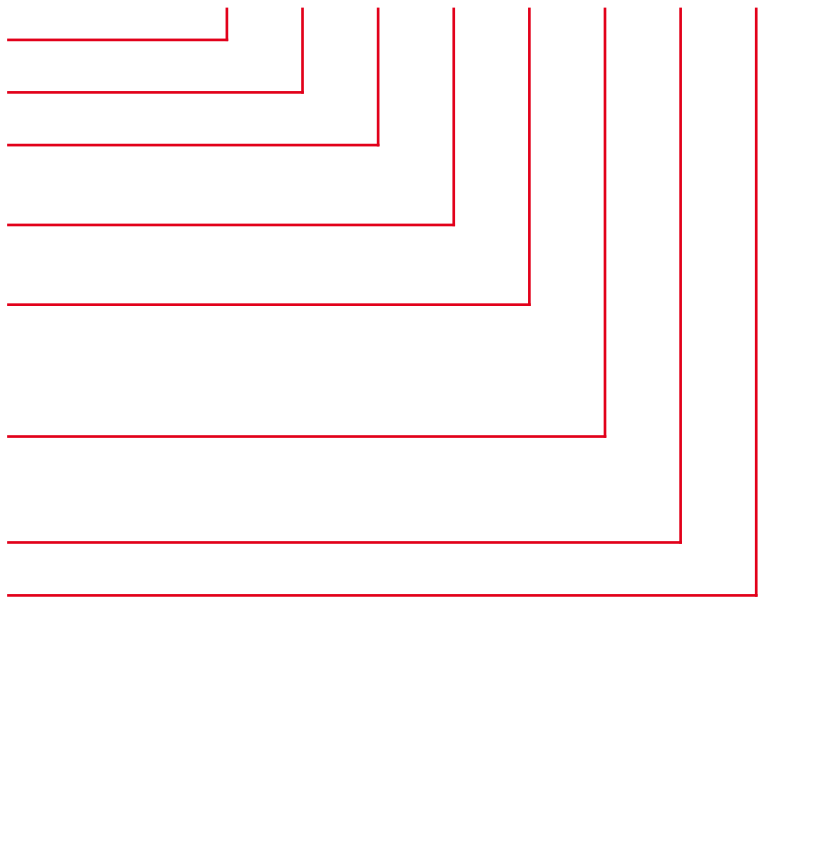

**International comparison of zones in areas with an explosion hazard**

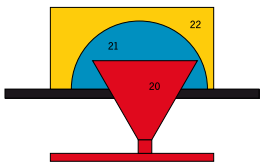
Country	Standard	Zone/division		
AS	AS 2430.2:1986	Class II		
GB	BS6467.2:1988	Z	Y	
DE	VDE 0165:1991	10	11	
USA	NEC 500-6: 2002	Div. 1	Div.2	
EU	EN50281-3:2002	20	21	22
INT	IEC 61241-10:2004	20	21	22
EU	EN 61241-10:2005			
		Area in which an explosive atmosphere in the form of a cloud of combustible dust in air is present continuously, or for long periods or frequently.	Area in which an explosive atmosphere in the form of a cloud of combustible dust in air is likely to occur occasionally in normal operation.	Area in which during normal operation, it is not to be expected that an explosive atmosphere occurs in the form of a cloud of combustible dust in the air, if it does occur, however, only for a brief time.



## Protection classification

### Design

Protection classification

Pneumatic chain hoist model CPA ATEX 1-13 up to 10-9

Pneumatic chain hoist model CPA ATEX 20-8 up to 100-2

Hand chain hoist model Yalelift 360 ATEX

Hand chain hoist with integrated push or geared type trolley model Yalelift 360 IT ATEX

Hand chain hoist with integrated push or geared type trolley (low headroom) model Yalelift 360 LH ATEX

Push and geared type trolley model HTP/G ATEX

Ratchet lever hoist model UNOplus ATEX

Electric winch model BETA-EX





Sheave block for rope guidance model DSRBX S

Hand winch with load pressure brake model OMEGA-EX

Rack and pinion jack model ZWW-EX

Hand pallet truck, stainless steel version model HU 20-115 VATP ATEX PROLINE



	BASIC	MEDIUM	HIGH	SPECIAL
	 II 3 GD c IIB T4/ II 2 GD c IIA T4	 II 2 GD c (de) (ck) IIB T4	 II 2 GD c IIC T4	 I M2
	X	X on request		
	X	X	X	
	X	X	X	
	X	X	X	
	X	X	X	
	X only II 3 GD c IIB T4			X
		X (de)		
		X		
		X (ck)		
		X		
			X	



Due to the use of stainless steel load chains for the **HIGH** design a reduction of the load capacity is necessary. Please see the table „technical data“ for the appropriate values.

**BASIC**

- Load chain galvanic zinc-plated, stainless steel hand chain
- Trolleys with buffer
- Brake with cooling element (only for model Yalelift)

**MEDIUM**

- Load chain galvanic zinc-plated, stainless steel hand chain
- Top and load hook copper-plated
- Trolley equipped with buffers and bronze trolley wheels
- Brake with cooling element (only for model Yalelift)

**HIGH**

- Stainless steel load and hand chain
- Load and top hook copper-plated
- Trolley equipped with buffers and bronze trolley wheels
- Brake with cooling element (only for model Yalelift)
- Conductive load rollers (only hand pallet truck)

**SPECIAL**

- Only for mining industry



## Pneumatic chain hoist model CPA ATEX

Capacity 125 - 980 kg

Pneumatic chain hoists are characterized by high durability in a great number of industrial applications. The robust housing allows an easy transport.

### Features

- Designed for operating pressures of 5 to 7 bar.
- Rotating piston motor with 100 % duty rating and an unlimited number of starts for continuous operation.
- Integrated limit switches for highest and lowest hook position as standard.
- Self-adjusting automatic disc brake, maintenance-free.
- Extremely sensitive control with emergency-stop for a precise positioning of the load.
- Air release for brake as standard for models CPA 2-31, CPA 5-17 and CPA 10-9

### Options

- Manual and powered trolleys with shackle to fit top hook suspended pneumatic chain hoists.
- All models available with push or geared trolley.
- Models CPA 2-31, CPA 5-17 and CPA 10-9 with pneumatic trolley on request.
- Models CPA 2-31, CPA 5-17 and CPA 10-9 also available for operation in hazardous areas, category 2 (Zone 1/21).
- Models CPA 2-31, CPA 5-17 and CPA 10-9 also available with chain control.
- Maintenance unit for main air supply pipe (pressure regulator, manometer, lubricator and support).
- Chain container

### Applications

Automobile and aircraft industries, shipyards, on ships and docks. Foundries, on/offshore, paint factories and paint shops, refineries, oil depots, galvanizing. Printing, textile and food industries, pulp, paper and cement mills. Glass and ceramic industries, wood working industries, chemical industries, heat treatment and power plants etc.

Also suitable for operation with nitrogen.

To ensure faultless operation the compressed air supply must be filtered and oiled.



## Technical data model CPA ATEX

Model	EAN-No. 401750917*	Capacity in kg/ Number of chain falls	Lifting speed with related load*	Lifting speed without load*	Lowering speed with related load*	Air consumption with rated load*	Hoist motor	Weight at 3 m lift
			m/min	m/min	m/min	m <sup>3</sup> /min.	kW	kg
CPA ATEX 1-13	*911795	125/1	13,1	17,1	11,3	0,9	0,4	15,4
CPA ATEX 2-10	*911788	250/1	9,8	17,1	13,7	0,9	0,4	15,4
CPA ATEX 2-31	*911801	250/1	31,0	52,0	36,0	1,98	1,33	21,8
CPA ATEX 5-5	*911818	500/2	4,6	7,9	6,7	0,9	0,4	17,2
CPA ATEX 5-17	*911825	500/1	16,8	32,3	29,6	1,27	1,33	21,8
CPA ATEX 10-9	*911832	980/2	8,5	16,2	14,9	1,27	1,33	27,7

\*Values for 6.3 bar (flow pressure) and 2 m control drop. Speeds will be reduced in case of longer control length.

Model CPA 1-13, CPA 2-10 and CPA 5-5 max. hose length 12 m, model CPA 2-31, CPA 5-17 and CPA 10-9 max. hose length 20 m.

## Dimensions model CPA ATEX

Model	CPA ATEX 1-13	CPA ATEX 2-10	CPA ATEX 2-31	CPA ATEX 5-5	CPA ATEX 5-17	CPA ATEX 10-9
A, mm	292	292	457	324	457	457
A1, mm	410	410	483	410	483	508
B, mm	21	21	25	14	25	27
C, mm	20	20	24	24	24	28
D, mm	16	16	26	14	26	28
F1, mm	90	90	130	90	130	130
F2, mm	120	120	180	120	180	180
K, mm	103	103	146	103	146	165
L, mm	57	57	102	57	102	83
M, mm	120	120	114	120	114	135
N, mm	50	50	54	50	54	25
Q1, mm	142	142	162	142	162	162
Q2, mm	183	183	181	183	181	181

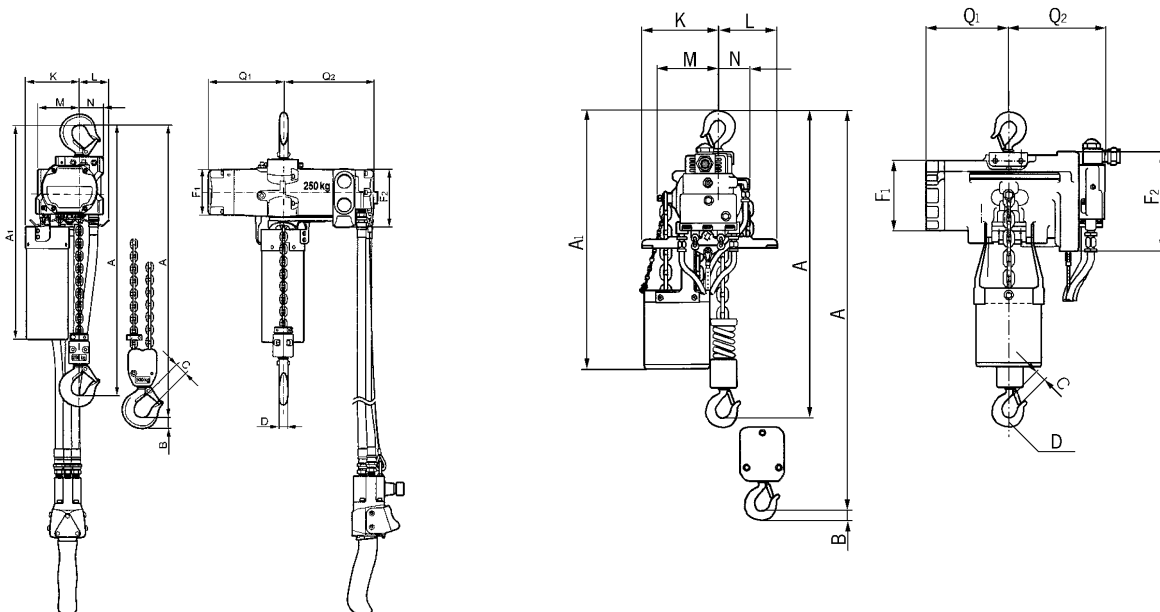

Model CPA ATEX 1-13 / 2-10 / 5-5

Model CPA ATEX 2-31 / 5-17 / 10-9



Image shows  
BASIC design

Image shows  
MEDIUM design  
incl. rope control

**To ensure faultless operation  
the compressed air supply must be  
filtered and oiled!**

## Pneumatic chain hoist with suspension hook or with integrated trolley model CPA ATEX

Capacity 2.000 - 10.000 kg

With 100 % duty rating and an unlimited number of starts the model CPA is suitable for heavy duty applications. It is insusceptible to contamination, humidity and aggressive mediums from the outside. The hoists are composed of three main components which makes service easy and inexpensive.

### Features

- Designed for operating pressures of 4 to 6 bar.
- Robust rotating piston motor has an adjustable spring pressure brake that holds the load secure even in the event of an air failure.
- The standard, oil bath lubricated planetary gearbox is particularly smooth running and enables a low overall height.
- High starting torque due to switching valves in the motor body.
- Low noise emission due to large dimension silencer.
- Sensitive control by means of 2 resp. 4 button pendant control with emergency stop.
- The assembly of component parts result in a low overall height (up to 3000 kg only one chain fall).
- The 5-pocket load chain sheave, manufactured from wear resistant case hardening steel, is matched perfectly to the load chain to guarantee smooth and precise chain motion.
- Drop forged suspension and load hooks are made from non-aging, high tensile steel and fitted with robust safety latches.
- The standard case hardened and zinc-plated link chain is matched perfectly to the load chain to guarantee smooth and precise chain motion.
- All requirements of national and international standards and regulations are fulfilled.
- Copper-coated suspension and load hooks for MEDIUM design or higher.
- Stainless steel load chain for HIGH design.

### Options

- Trolley for suspension hook version or integrated trolleys for all three designs (BASIC, MEDIUM, HIGH).
- Rope control
- Limit switch
- Chain container

**Technical data model CPA ATEX BASIC II 3 GD c IIB T4 / II 2 GD c IIA T4**

Model	EAN-No. 401950919*	Capacity in kg/ Number of chain falls	Lifting speed with related load*	Lifting speed without load*	Lowering speed with related load*	Hoist motor	Weight** suspension hook	Weight** push trolley	Weight** geared trolley	Weight** pneumatic trolley
			m/min	m/min	m/min	kW	kW	kg	kg	kg
CPA ATEX 20-8	*377942	2.000/1	7,4	9,9	11,0	2,6	121	184	188	199
CPA ATEX 30-6	*377959	3.000/1	6,0	9,9	13,0	3,2	121	184	188	199
CPA ATEX 40-4	*377966	4.000/2	3,7	5,0	5,5	2,6	140	202	206	218
CPA ATEX 50-3	*377973	5.000/2	3,4	5,0	6,0	3,0	140	202	206	218
CPA ATEX 75-2	*377980	7.500/3	2,0	3,3	4,3	3,2	-	-	-	-
CPA ATEX 100-3	*377997	10.000/4	3,4	5,0	6,0	2 x 3,0	-	-	-	-

**Technical data model CPA ATEX MEDIUM II 2 GD c IIB T4**

Model	EAN-No. 401950919*	Capacity in kg/ Number of chain falls	Lifting speed with related load*	Lifting speed without load*	Lowering speed with related load*	Hoist motor	Weight** suspension hook	Weight** push trolley	Weight** geared trolley	Weight** pneumatic trolley
			m/min	m/min	m/min	kW	kW	kg	kg	kg
CPA ATEX 20-8	*393690	2.000/1	7,4	9,9	11,0	2,6	121	184	188	199
CPA ATEX 30-6	*409438	3.000/1	6,0	9,9	13,0	3,2	121	184	188	199
CPA ATEX 40-4	*409469	4.000/2	3,7	5,0	5,5	2,6	140	202	206	218
CPA ATEX 50-3	*409483	5.000/2	3,4	5,0	6,0	3,0	140	202	206	218
CPA ATEX 75-2	*410175	7.500/3	2,0	3,3	4,3	3,2	-	-	-	-
CPA ATEX 100-3	*409520	10.000/4	3,4	5,0	6,0	2 x 3,0	-	-	-	-

**Technical data model CPA ATEX HIGH II 2 GD c IIC T4**

Model	EAN-No. 401950919*	Capacity in kg/ Number of chain falls	Lifting speed with related load*	Lifting speed without load*	Lowering speed with related load*	Hoist motor	Weight** suspension hook	Weight** push trolley	Weight** geared trolley	Weight** pneumatic trolley
			m/min	m/min	m/min	kW	kW	kg	kg	kg
CPA ATEX 20-8	*409872	2.000/1	7,4	9,9	11,0	2,6	121	184	188	199
CPA ATEX 40-4	*409995	4.000/2	3,7	5,0	5,5	2,6	140	202	206	218
CPA ATEX 75-2	*410045	7.500/3	2,0	3,3	4,3	3,2	-	-	-	-
CPA ATEX 100-3	*409926	8.000/4	3,4	5,0	6,0	2 x 3,0	-	-	-	-

\*Values for 6 bar (flow pressure), air consumption with rated load 4.7 m<sup>3</sup>/min. For CPA 100-2: 9.4 m<sup>3</sup>/min.

\*\*Weight for standard 3 m lift. Other lifting heights on request.

\*\*\*Models in HIGH design are already labelled with reduced capacities when delivered.

**Technical data trolleys**

Capacity	Size	Beam flange width b	Beam flange thickness t max.	Curve radius min.	Pneumatic trolley travel speed	Pneumatic trolley motor
kg		mm	mm	m	m/min	kW
2.000 - 6.000	A	98 - 180	27	2,0	18	0,55
2.000 - 6.000	B	180 - 300	27	1,8	18	0,55
7.500 - 10.000	B	125 - 310	40	1,8	-	-

## Dimensions model CPA ATEX

Model	CPA ATEX 20-8	CPA ATEX 30-6	CPA ATEX 40-4	CPA ATEX 50-3	CPA ATEX 60-3	CPA ATEX 75-2	CPA ATEX 100-2
A, mm	516	516	681	681	681	950	1.068
A1, mm	286	286	428	428	428	479	651
B, mm	35	35	45	45	47	60	60
C, mm	37	37	46	46	42	52	52
D, mm	24	24	30	30	30	40/45	40/45
F1, mm	160	160	160	160	160	160	160
F2, mm	165	165	165	165	165	165	165
G, mm	220	220	220	220	220	220	581
G1, mm	180	180	140	140	140	268	311
G2 (13 m), mm	258	258	218	218	218	-	-
G2 (21 m), mm	278	278	238	238	238	345	408
H1, mm	110	110	110	110	110	110	110
H2, mm	135	135	135	135	135	307	256
H3, mm	115	115	115	115	115	115	115
K1, mm	100	100	100	100	100	92	92
K2, mm	51	51	51	51	51	62	62
M, mm	50	50	9,6	9,6	9,6	139	181
N, mm	60	60	100	100	100	136	291
Q1, mm	272	272	272	272	272	272	272
Q2, mm	325	325	325	325	325	325	325

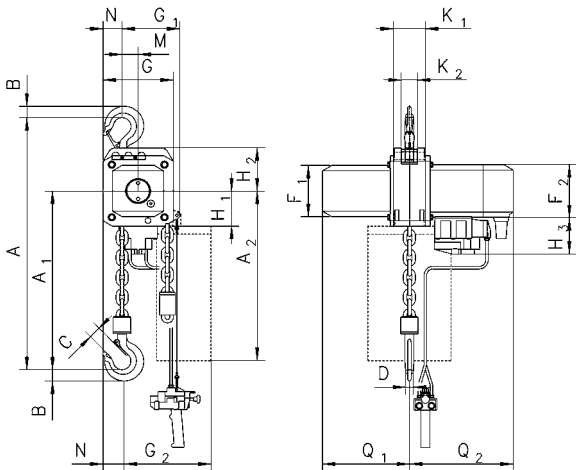

Model CPA ATEX with suspension hook, 2000 - 3000 kg, single fall

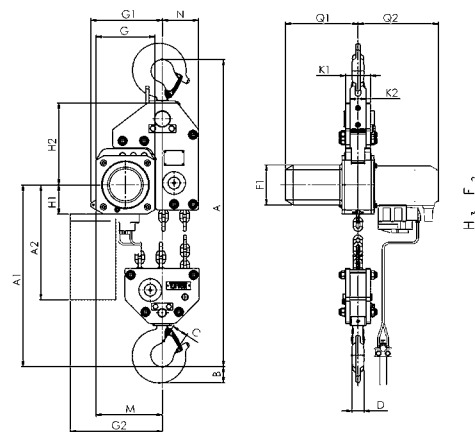

Model CPA ATEX with suspension hook, 7500 kg, three fall

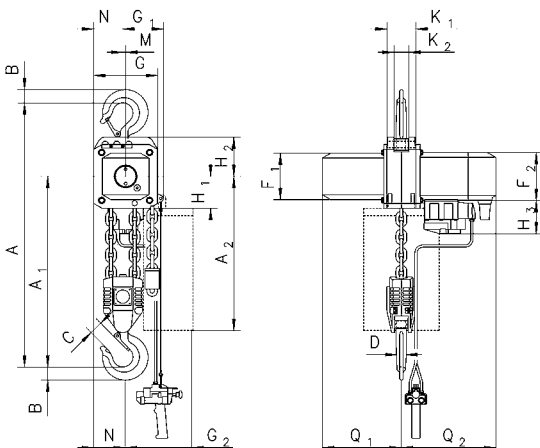

Model CPA ATEX with suspension hook, 4000 - 6000 kg, double fall

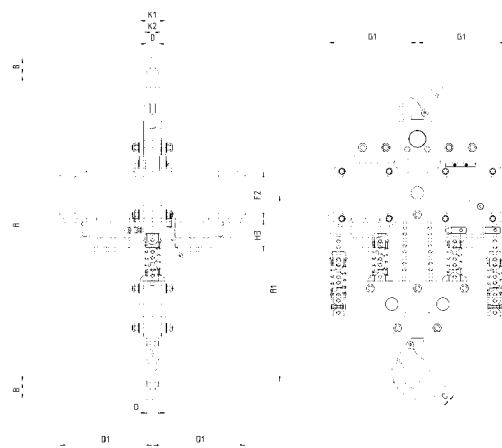

Model CPA ATEX with suspension hook, 10000 kg, four fall

## Dimensions model CPA ATEX

Model	CPA ATEX 20-8	CPA ATEX 30-6	CPA ATEX 40-4	CPA ATEX 50-3	CPA ATEX 60-3	CPA ATEX 75-2	CPA ATEX 100-2
A2 (13 m), mm	430	430	430	430	430	-	-
A2 (21 m), mm	530	530	530	530	530	530	530
A4, mm	465	465	615	615	615	855	965
A5, mm	298	298	298	298	298	477	425
A6, mm	190	190	190	190	190	182	182
b, mm	A = 98 - 180 / B = 180 - 300	A = 98 - 180 / B = 180 - 300	A = 98 - 180 / B = 180 - 300	A = 98 - 180 / B = 180 - 300	A = 98 - 180 / B = 180 - 300	125 - 310	125 - 310
F, mm	150	150	150	150	150	113	113
l, mm	142,5	142,5	142,5	142,5	142,5	130	130
L1, mm	209	209	209	209	209	200	200
L2, mm	262,5	262,5	262,5	262,5	262,5	215	215
L3, mm	265	265	265	265	265	265	265
L4, mm	213	213	253	253	253	291	291
L5, mm	312	312	272	272	272	-	-
L6, mm	315	315	275	275	275	-	-
O, mm	125	125	125	125	125	150	150
P, mm	208	208	208	208	208	208	208
P1, mm	284	284	284	284	284	284	284
S, mm	b + 70	b + 70	b + 70	b + 70	b + 70	b + 98	b + 98
t, mm	27	27	27	27	27	40	40
T1 Größe A	182	182	182	182	182	-	-
T1 Größe B	242	242	242	242	242	270	270

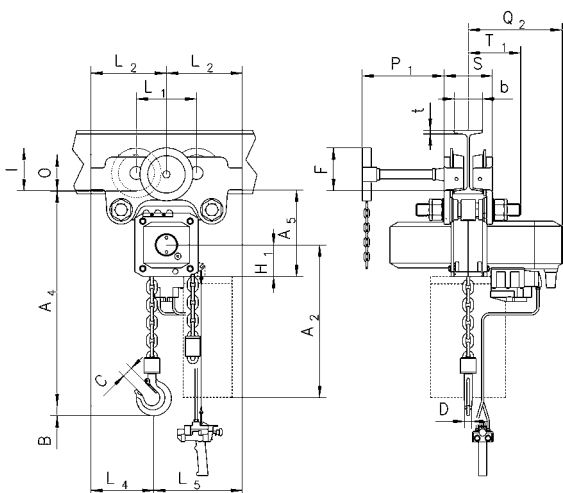

Model CPA ATEX with integrated manual push or geared trolley

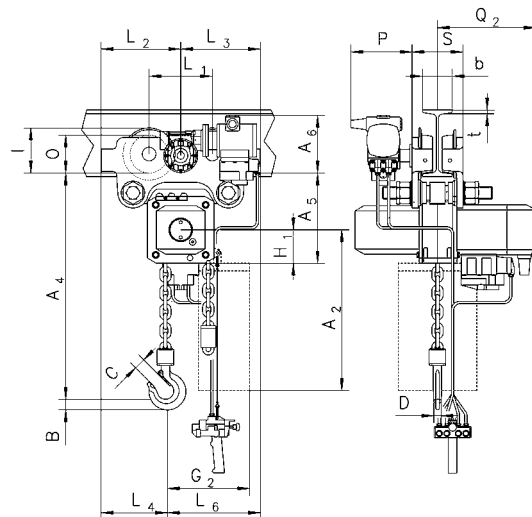

Model CPA ATEX with integrated pneumatic trolley



*Patented!  
Rotating  
hand chain  
guide!*

Image shows  
MEDIUM design

**Easy modification from Yalelift 360 ATEX  
to Yalelift IT ATEX is possible.**

## Hand chain hoist model Yalelift 360 ATEX

Capacity 500 - 20.000 kg

The hand chain hoist model Yalelift 360 ATEX once again proves its worth in an environment that far exceeds the requirements of a classical hand chain hoist. On the basis of the European Directive 94/9/EG this model series has been further developed for the use in potentially explosive atmospheres (ATEX zones).

### Features

- The enclosed robust stamped steel housing protects all internal components even in the toughest conditions.
- The extremely low headroom allows maximum use of the lifting height.
- The revolutionary 360° rotating hand chain guide allows the operator to work from virtually any position, in confined spaces or above the load. The Yalelift can even be operated from the side of the load which also makes it possible to use the hoist for horizontal pulling or tensioning. Due to the additional flexibility, the operator is no longer forced to work in the danger zone near the load.
- The brake system is extremely quiet and guarantees operational safety and improved serviceability due to omission of the vulnerable ratchet pawls. All parts are made of high quality materials, additionally zinc-plated or yellow-chromated to increase corrosion prevention.
- Chain guide and gearbox are almost totally enclosed. Even under the toughest conditions the internal gearbox remains protected.
- The hardened load sheave with four precision machined pockets ensures accurate movement of the load chain.
- The surface protected zinc-plated alloy steel load chains fulfil all requirements of current national and international standards and regulations. They are matched perfectly to the load chain sheave and guarantee smooth and precise chain motion.
- Drop forged load and suspension hooks that yield under overload instead of breaking, are made of high tensile steel. The hooks are fitted with robust safety latches and rotate 360°.
- Explosion protected version with spark resistant coating.
- Copper-coated suspension and load hooks for MEDIUM design or higher.
- Stainless steel load chain for HIGH design.

### Options

- Adjustable overload prevention device
- Chain container

**Technical data model Yalelift 360 ATEX BASIC II 3 GD c IIB T4 / II 2 GD c IIA T4**

Model	EAN-NO. 402350923*	Capacity in kg/ number of chain falls	Chain dimensions d x p mm	Load chain grade	Hand chain overhaul for 1 m lift m	Pull on hand chain at WLL daN	Weight at standard lift (3 m) kg
YL ATEX 500	*194969	500/1	5 x 15	T	30	21	9
YL ATEX 1000	*198196	1.000/1	6 x 18	T	49	30	13
YL ATEX 2000	*199872	2.000/1	8 x 24	T	71	32	20
YL ATEX 3000	*210522	3.000/1	10 x 30	T	87	38	29
YL ATEX 5000	*218672	5.000/2	10 x 30	T	174	34	38
YL ATEX 10000	*224611	10.000/3	10 x 30	V	261	44	71
YL ATEX 20000	*225625	20.000/6	10 x 30	V	522	2 x 44	196

**Technical data model Yalelift 360 ATEX MEDIUM II 2 GD c IIB T4**

Model	EAN-NO. 402350923*	Capacity in kg/ number of chain falls	Chain dimensions d x p mm	Load chain grade	Hand chain overhaul for 1 m lift m	Pull on hand chain at WLL daN	Weight at standard lift (3 m) kg
YL ATEX 500	*206365	500/1	5 x 15	T	30	21	9
YL ATEX 1000	*206419	1.000/1	6 x 18	T	49	30	13
YL ATEX 2000	*206426	2.000/1	8 x 24	T	71	32	20
YL ATEX 3000	*206440	3.000/1	10 x 30	T	87	38	29
YL ATEX 5000	*206464	5.000/2	10 x 30	T	174	34	38
YL ATEX 10000	*239547	10.000/3	10 x 30	V	261	44	71
YL ATEX 20000	*251846	20.000/6	10 x 30	V	522	2 x 44	196

**Technical data model Yalelift 360 ATEX HIGH II 2 GD c IIC T4**

Model	EAN-NO. 402350923*	Capacity*** in kg/ number of chain falls	Chain dimensions d x p mm	Load chain grade	Hand chain overhaul for 1 m lift m	Pull on hand chain at WLL daN	Weight at standard lift (3 m) kg
YL ATEX 500	*929806	500/1	5 x 15	S	30	21	9
YL ATEX 1000	*929790	900/1	6 x 18	S	49	30	13
YL ATEX 2000	*929783	1.250/1	8 x 24	P	71	32	20
YL ATEX 3000	*929776	2.000/1	10 x 30	P	87	38	29
YL ATEX 5000	*929769	4.000/2	10 x 30	P	174	34	38
YL ATEX 10000	*929752	6.000/3	10 x 30	P	261	44	71
YL ATEX 20000	*929745	12.000/6	10 x 30	P	522	2 x 44	196

\*\*\*Models in HIGH design are already labelled with reduced capacities when delivered.



## Dimensions model Yalelift 360 ATEX

Model	YL ATEX 500	YL ATEX 1000	YL ATEX 2000	YL ATEX 3000	YL ATEX 5000	YL ATEX 10000	YL ATEX 20000
Amin, mm	300	335	395	520	654	825	1.010
B, mm	17	22	30	38	45	68	85
C, mm	24	29	35	40	47	68	64
D, mm	133	156	182	220	220	220	303
E, mm	148	175	203	250	250	283	555
F, mm	139	157	183	204	204	204	250
G, mm	139	164	192	225	242	326	391
H, mm	206	242	283	335	352	436	501
I, mm	24	24	31	34	21	136	-
K, mm	61	70	83	95	95	95	396
L, mm	79	87	100	109	109	109	125
M, mm	110	125	156	178	285	401	471
N, mm	14	19	22	30	37	50	56

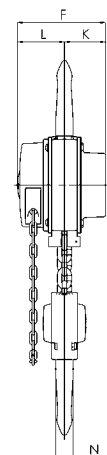
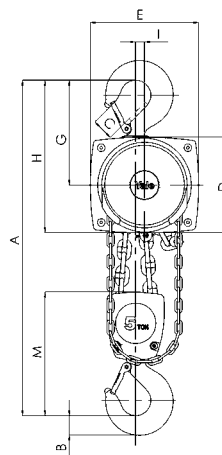
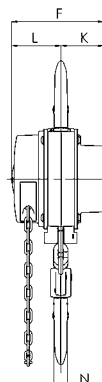
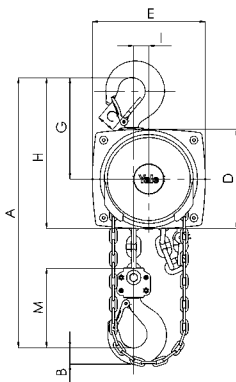

Model Yalelift 360 ATEX, 500 - 3000 kg, single fall

Model Yalelift 360 ATEX, 5000 kg, double fall

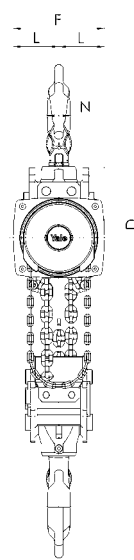
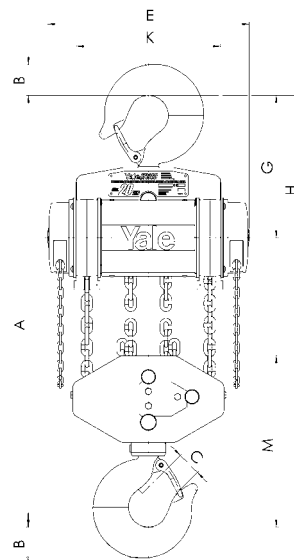
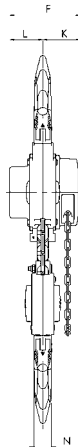
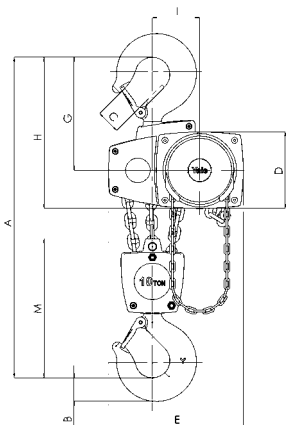

Model Yalelift 360 ATEX, 10000 kg, three fall

Model Yalelift 360 ATEX, 20000 kg, six fall







Image shows  
HIGH design

## **Hand chain hoist with integrated push or geared type trolley model Yalelift IT ATEX**

Capacity 500 - 20.000 kg

The combination of the Yalelift 360 with a low headroom manual trolley provides even more flexibility in the application of the Yalelift 360.

### **Features**

- All units of this series up to a capacity of 3000 kg are provided with single chain fall and the min. headroom (Dim. A) has been further reduced. Ideal for applications with low ceilings and limited headroom.
- The proven and almost stepless adjustment system allows quick and easy assembly of the trolley.
- Trolleys up to 5 t are offered for two beam ranges. Range A for a flange width up to 180 mm is standard and covers approx. 80 % of all requirements. Conversion to range B for beam width up to 300 mm can be easily accomplished.
- The trolley wheels (only for MEDIUM and HIGH design) are designed for a max. beam profile incline of 14 % (DIN 1025-1), excellent rolling features are guaranteed by prelubricated, encapsulated ball bearings.
- Anti-drop and anti-tilt devices as standard.
- Explosion protected version with spark resistant coating.
- Trolleys equipped with rubber buffers.
- Copper-coated load hooks for MEDIUM design or higher.
- Stainless steel load chain for HIGH design.

### **Options**

- Adjustable overload prevention device
- Chain container
- Beam locking device to secure the unloaded trolley in a fixed position on the beam (park position e.g. on ships).

Technical data model Yalelift ITP ATEX BASIC with integrated push type trolley II 3 GD c IIB T4 / II 2 GD c IIA T4

Model	EAN-No. 4025092*	Capacity in kg/ Number of chain falls	Size*	Beam flange width b mm	Beam flange thickness t max. mm	Min. curve radius m	Weight*	Weight** with beam brake kg
YLITP ATEX 500	*237253	500 / 1	A	50 - 180	19	0,9	20	26
YLITP ATEX 1000	*237864	1.000 / 1	A	50 - 180	19	0,9	27	35
YLITP ATEX 2000	*243131	2.000 / 1	A	58 - 180	19	1,15	44	52

Technical data model Yalelift ITP ATEX MEDIUM with integrated push type trolley II 2 GD c IIB T4

Model	EAN-No. 4025092*	Capacity in kg/ Number of chain falls	Size*	Beam flange width b mm	Beam flange thickness t max. mm	Min. curve radius m	Weight*	Weight** with beam brake kg
YLITP ATEX 500	*205177	500 / 1	A	50 - 180	19	0,9	20	26
YLITP ATEX 1000	*205382	1.000 / 1	A	50 - 180	19	0,9	27	35
YLITP ATEX 2000	*206310	2.000 / 1	A	58 - 180	19	1,15	44	52

Technical data model Yalelift ITP ATEX HIGH with integrated push type trolley II 2 GD c IIC T4

Model	EAN-No. 4025092*	Capacity*** in kg/ Number of chain falls	Size*	Beam flange width b mm	Beam flange thickness t max. mm	Min. curve radius m	Weight*	Weight** with beam brake kg
YLITP ATEX 500	*257688	500 / 1	A	50 - 180	19	0,9	20	26
YLITP ATEX 1000	*257787	900 / 1	A	50 - 180	19	0,9	27	35
YLITP ATEX 2000	*258760	1.250 / 1	A	58 - 180	19	1,15	44	52

\*Size B on request

\*\*Weight for standard 3 m lift. Other lifting heights available.

\*\*\*Models in HIGH design are already labelled with reduced capacities when delivered.

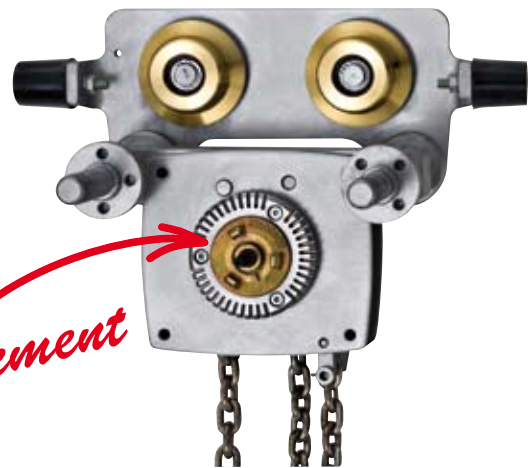

**Yale hoists and trolleys are not designed for passenger elevation applications and must not be used for this purpose.**

**Technical data model Yalelift ITG ATEX BASIC with integrated geared type trolley II 3 GD c IIB T4 / II 2 GD c IIA T4**

Model	EAN-No. 4025092*	Capacity in kg/ Number of chain falls	Size*	Beam flange width b mm	Beam flange thickness t max. mm	Min curve radius m	Weight* kg	Weight** with beam brake kg
YLITG ATEX 500	*253055	500 / 1	A	50 - 180	19	0,9	24	31
YLITG ATEX 1000	*929844	1.000 / 1	A	50 - 180	19	0,9	32	40
YLITG ATEX 2000	*929837	2.000 / 1	A	58 - 180	19	1,15	49	57
YLITG ATEX 3000	*929820	3.000 / 1	A	74 - 180	27	1,5	82	91
YLITG ATEX 5000	*929813	5.000 / 2	A	98 - 180	27	2,0	130	140
YLITG ATEX 10000	*941112	10.000 / 3	B	125 - 310	40	1,8	on request	on request
YLITG ATEX 20000	*941556	20.000 / 6	B	180 - 310	40	5,0	on request	on request

**Technical data model Yalelift ITG ATEX MEDIUM with integrated geared type trolley II 2 GD c IIB T4**

Model	EAN-No. 4025092*	Capacity in kg/ Number of chain falls	Size*	Beam flange width b mm	Beam flange thickness t max. mm	Min curve radius m	Weight** kg	Weight** with beam brake kg
YLITG ATEX 500	*206334	500 / 1	A	50 - 180	19	0,9	24	31
YLITG ATEX 1000	*206341	1.000 / 1	A	50 - 180	19	0,9	32	40
YLITG ATEX 2000	*206358	2.000 / 1	A	58 - 180	19	1,15	49	57
YLITG ATEX 3000	*206549	3.000 / 1	A	74 - 180	27	1,5	82	91
YLITG ATEX 5000	*206563	5.000 / 2	A	98 - 180	27	2,0	130	140
YLITG ATEX 10000	*520072	10.000 / 3	B	125 - 310	40	1,8	on request	on request
YLITG ATEX 20000	*419765	20.000 / 6	B	180 - 310	40	5,0	on request	on request

**Technical data model Yalelift ITG ATEX HIGH with integrated geared type trolley II 2 GD c IIC T4**

Model	EAN-No. 4025092*	Capacity*** in kg/ Number of chain falls	Size*	Beam flange width b mm	Beam flange thickness t max. mm	Min curve radius m	Weight** kg	Weight** with beam brake kg
YLITG ATEX 500	*273626	500 / 1	A	50 - 180	19	0,9	24	31
YLITG ATEX 1000	*273633	900 / 1	A	50 - 180	19	0,9	32	40
YLITG ATEX 2000	*273640	1.250 / 1	A	58 - 180	19	1,15	49	57
YLITG ATEX 3000	*273657	2.000 / 1	A	74 - 180	27	1,5	82	91
YLITG ATEX 5000	*273664	4.000 / 2	A	98 - 180	27	2,0	130	140
YLITG ATEX 10000	*941938	6.000 / 3	B	125 - 310	40	1,8	on request	on request
YLITG ATEX 20000	*941945	12.000 / 6	B	180 - 310	40	5,0	on request	on request

\*Size B on request

\*\*Weight for standard 3 m lift. Other lifting heights available.

\*\*\*Models in HIGH design are already labelled with reduced capacities when delivered.

## Dimensions model Yalelift IT ATEX

Model	YLIT ATEX 500	YLIT ATEX 1000	YLIT ATEX 2000	YLIT ATEX 3000	YLIT ATEX 5000	YLIT ATEX 10000
Amin, mm	245	272	323	382	550	784
A1, mm	158	178	205,5	252	260,5	380
A2, mm	-	-	-	-	-	-
B, mm	17	22	30	38	45	68
C, mm	24	29	35	40	47	68
D, mm	14	19	22	30	37	50
F (Geared), mm	92	92	91	107	149,5	113
H1, mm	24,5	24	23,5	32	30,5	55
I (Pushed), mm	71,5	71,5	95,5	131	142,5	169
I (Geared), mm	76,5	76,5	98	132,5	148,5	169
L, mm	270	310	360	445	525	430
L1, mm	130	130	150	180	209	200
L2, mm	159	175	207	256	283	261
M, mm	M 18	M 22	M 27	M 30	M 42	M 48
O, mm	60	60	80	112	125	150
P (Geared), mm	108	110	112	112	117	158
T (area A), mm	280	290	305	320	-	-
T (area B), mm	400	410	425	440	484	540

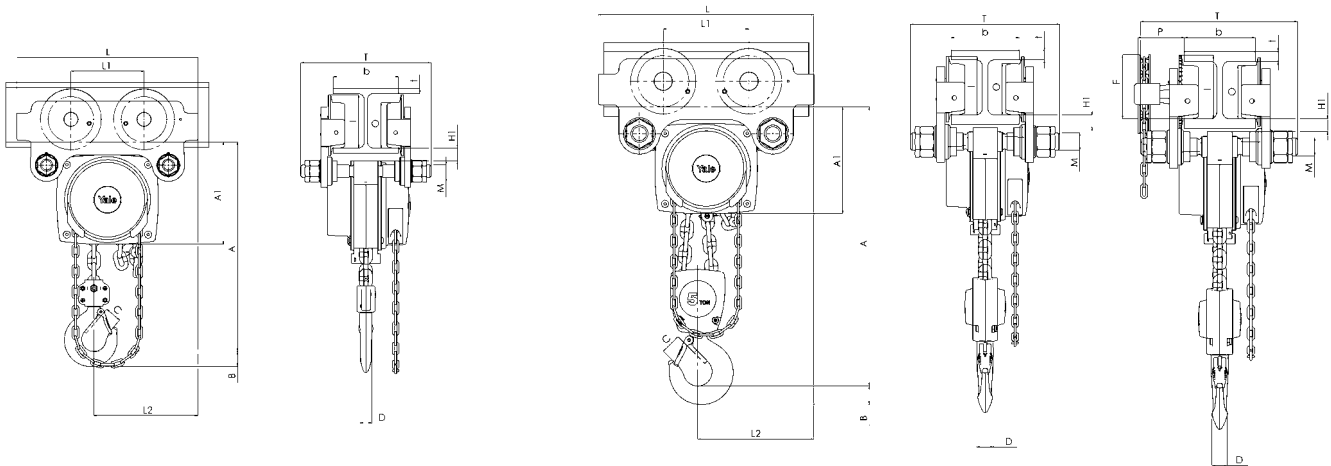

Model Yalelift ITP ATEX, 500 - 3000 kg, single fall

Model Yalelift ITP/ITG ATEX 5000 kg, double fall

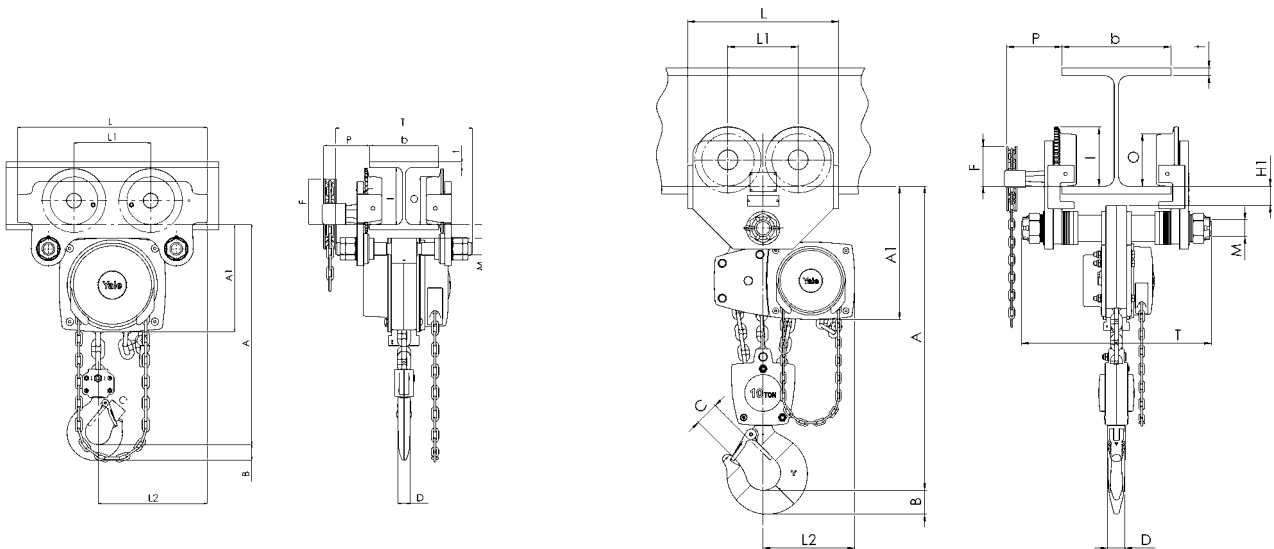

Model Yalelift ITG ATEX, 500 - 3000 kg, single fall

Model Yalelift ITG ATEX, 10000 kg, three fall



Image shows  
HIGH design

## Hand chain hoist with integrated push or geared type trolley (low headroom) model Yalelift LH ATEX

Capacity 500 - 10.000 kg

The hand chain hoist model Yalelift LH with integrated low headroom manual trolley is the consequent further development of the Yalelift IT. Wherever an even smaller headroom is essential, the Yalelift LH is the ideal choice.

### Features

- The specially developed chain reeving system and chain guide allow the bottom block to be pulled laterally to the hoist even further up and almost against the beam flange.
- The integrated design of the innovative Yalelift LH uses the same manual trolleys as incorporated in the Yalelift IT series.
- All models of the LH series up to 3000 kg capacity are provided with single chain fall.
- The proven and almost stepless adjustment system allows quick and easy assembly of the trolley.
- The trolleys up to 5 t are offered for two beam ranges. Range A for a flange width up to 180 mm is standard and covers approx. 80 % of all requirements. Conversion to range B for beam width up to 300 mm can be easily accomplished.
- The trolley wheels (only for MEDIUM and HIGH design) are designed for a max. beam profile incline of 14 % (DIN 1025-1), excellent rolling features are guaranteed by prelubricated, encapsulated ball bearings.
- The low headroom version of the Yalelift IT is adjustable to fit a wide range of beam profiles (e. g. INP, IPE, IPB).
- Anti-drop and anti-tilt devices as standard.
- Explosion protected version with spark resistant coating.
- Trolleys equipped with rubber buffers.
- Copper-coated load hooks for MEDIUM design or higher.
- Stainless steel load chain for HIGH design.

### Options

- Adjustable overload prevention device
- Chain container
- Beam locking device to secure the unloaded trolley in a fixed position on the beam (park position e.g. on ships).

**Technical data model Yalelift LHP ATEX BASIC with integrated push type trolley II 3 GD c IIB T4 / II 2 GD c IIA T4**

Model	EAN-No. 4025092*	Capacity in kg/ Number of chain falls	Size	Beam flange width b mm	Beam flange thickness t max. mm	Min curve radius m	Weight* kg	Weight* with beam brake kg
YLLHP ATEX 500	*377522	500 / 1	A	60 - 180	19	0,9	27	33
YLLHP ATEX 1000	*377539	1.000 / 1	A	70 - 180	19	0,9	35	43
YLLHP ATEX 2000	*377546	2.000 / 1	A	82 - 180	19	1,15	61	69

**Technical data model Yalelift LHP ATEX MEDIUM with integrated push type trolley II 2 GD c IIB T4**

Model	EAN-No. 4025092*	Capacity in kg/ Number of chain falls	Size	Beam flange width b mm	Beam flange thickness t max. mm	Min curve radius m	Weight* kg	Weight* with beam brake kg
YLLHP ATEX 500	*592291	500 / 1	A	60 - 180	19	0,9	27	33
YLLHP ATEX 1000	*592314	1.000 / 1	A	70 - 180	19	0,9	35	43
YLLHP ATEX 2000	*592321	2.000 / 1	A	82 - 180	19	1,15	61	69

**Technical data model Yalelift LHP ATEX HIGH with integrated push type trolley II 2 GD c IIC T4**

Model	EAN-No. 4025092*	Capacity*** in kg/ Number of chain falls	Size	Beam flange width b mm	Beam flange thickness t max. mm	Min curve radius m	Weight* kg	Weight* with beam brake kg
YLLHP ATEX 500	*377799	500 / 1	A	60 - 180	19	0,9	27	33
YLLHP ATEX 1000	*377829	900 / 1	A	70 - 180	19	0,9	35	43
YLLHP ATEX 2000	*377836	1.250 / 1	A	82 - 180	19	1,15	61	69

\*Size B on request

\*\*Weight for standard 3 m lift. Other lifting heights available.

\*\*\*Models in HIGH design are already labelled with reduced capacities when delivered.

## Technical data model Yalelift LHP ATEX BASIC with integrated geared type trolley II 3 GD c IIB T4 / II 2 GD c IIA T4

Model	EAN-No. 4025092*	Capacity in kg/ number of chain falls	Size*	Beam flange width b mm	Beam flange thickness t max. mm	Min. curve radius m	Weight** kg	Weight** with locking device kg
YLLH ATEX 500	*377744	500 / 1	A	60 - 180	19	0,9	31	38
YLLH ATEX 1000	*377768	1.000 / 1	A	70 - 180	19	0,9	40	48
YLLH ATEX 2000	*378697	2.000 / 1	A	82 - 180	19	1,15	65	73
YLLH ATEX 3000	*377782	3.000 / 1	A	100 - 180	19	1,5	112	121
YLLH ATEX 5000	*378703	5.000 / 2	A	110 - 180	27	2,0	157	167
YLLH ATEX 10000	*378727	10.000 / 3	B	180 - 310	40	1,8	232	on request

## Technical data model Yalelift LHG ATEX MEDIUM with integrated geared type trolley II 2 GD c IIB T4

Model	EAN-No. 4025092*	Capacity in kg/ number of chain falls	Size*	Beam flange width b mm	Beam flange thickness t max. mm	Min. curve radius m	Weight** kg	Weight** with locking device kg
YLLH ATEX 500	*594592	500 / 1	A	60 - 180	19	0,9	31	38
YLLH ATEX 1000	*594608	1.000 / 1	A	70 - 180	19	0,9	40	48
YLLH ATEX 2000	*594615	2.000 / 1	A	82 - 180	19	1,15	65	73
YLLH ATEX 3000	*594622	3.000 / 1	A	100 - 180	19	1,5	112	121
YLLH ATEX 5000	*594639	5.000 / 2	A	110 - 180	27	2,0	157	167
YLLH ATEX 10000	*941549	10.000 / 3	B	180 - 310	40	1,8	232	on request

## Technical data model Yalelift LHG ATEX HIGH with integrated geared type trolley II 2 GD c IIC T4

Model	EAN-No. 4025092*	Capacity*** in kg/ number of chain falls	Size*	Beam flange width b mm	Beam flange thickness t max. mm	Min. curve radius m	Weight** kg	Weight** with locking device kg
YLLH ATEX 500	*377843	500 / 1	A	60 - 180	19	0,9	31	38
YLLH ATEX 1000	*377867	900 / 1	A	70 - 180	19	0,9	40	48
YLLH ATEX 2000	*377874	1.250 / 1	A	82 - 180	19	1,15	65	73
YLLH ATEX 3000	*377898	2.000 / 1	A	100 - 180	19	1,5	112	121
YLLH ATEX 5000	*377911	4.000 / 2	A	110 - 180	27	2,0	157	167
YLLH ATEX 10000	*377928	6.000 / 3	B	180 - 310	40	1,8	232	on request

\*Size B on request

\*\*Weight for standard 3 m lift. Other lifting heights available.

\*\*\*Models in HIGH design are already labelled with reduced capacities when delivered.

**Yale hoists and trolleys are not designed for passenger elevation applications and must not be used for this purpose.**





## Dimensions model Yalelift LH ATEX

Model	YLLH ATEX 500	YLLH ATEX 1000	YLLH ATEX 2000	YLLH ATEX 3000	YLLH ATEX 5000	YLLH ATEX 10000
Amin, mm	188	211	264	316	425	565
A1, mm	223	250	289	346	345	365
A2, mm	381	427	511	614	612	665
B, mm	17	22	30	38	45	68
C, mm	24	29	35	40	47	68
D, mm	14	19	22	30	37	50
F (Geared), mm	92	92	91	107	150	150
H1, mm	24	24	24	32	31	45
I (Pushed), mm	72	72	96	131	143	170
I (Geared), mm	77	77	98	133	149	170
L, mm	270	310	360	445	525	485
L1, mm	130	130	150	180	209	225
L2, mm	444	488	582	690	720	805
L3, mm	124	135	172	203	175	215
L4, mm	184	201	230	265	283	348
M, mm	M 18	M 22	M 27	M 30	M 42	M 48
O, mm	60	60	80	112	125	150
P (Geared), mm	108	110	112	112	117	165
T (area A), mm	280	290	305	320	364	440
T (area B), mm	400	410	425	440	484	540

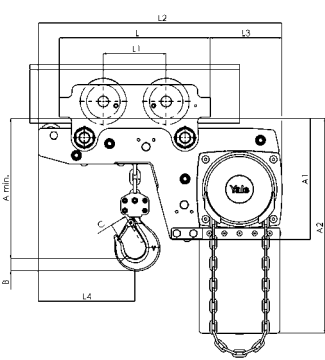

Model Yalelift LHP ATEX, 500 - 3000 kg, single fall

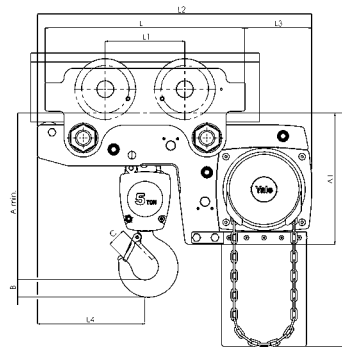

Model Yalelift LHP ATEX, 5000 kg, double fall

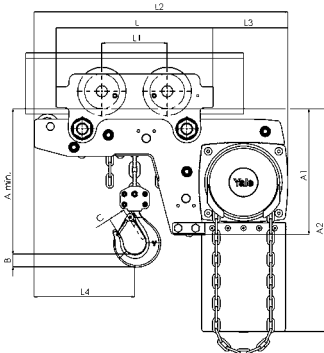
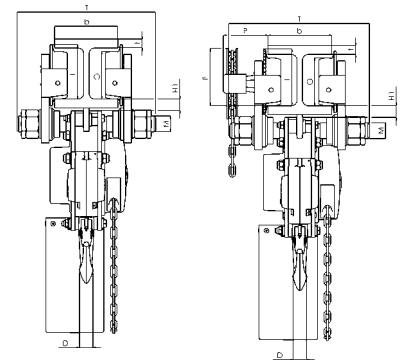

Model Yalelift LHG ATEX, 500 - 3000 kg, single fall

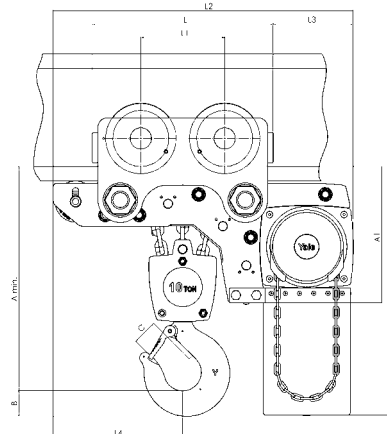

Model Yalelift LHG ATEX, 10000 kg, three fall



Image shows  
HIGH design

## Push and geared type model HTP/G ATEX

Capacity 500 - 20.000 kg

The trolley enables the exact positioning or easy traversing of large loads with either manual or powered hoisting equipment.

### Features

- The trolley wheels (only for HIGH design) are designed for a max. beam profile incline of 14 % (DIN 1025-1), excellent rolling features due to prelubricated and encapsulated ball bearings.
- Adjustable to fit a wide range of beam widths and profiles (e. g. INP, IPE and IPB).
- Adjustments are made by rotating the clevis load bar which also ensures the centred positioning of the hoist in the clevis – no creeping to the left or the right.
- Trolleys are in accordance with the UVV and machinery directives.
- Explosion protected version with spark resistant coating.
- Trolleys equipped with rubber buffers.
- Stainless steel hand chain for model HTG.

### Options

- Locking device to secure the trolley in position on the beam (park position e.g. on ships).

### Technical data model HTG ATEX BASIC II 3 GD c IIB T4 / II 2 GD c IIA T4

Model	EAN-No. 403450934*	Capacity kg	Size	Beam flange width b mm	Beam flange thickness t mm	Min. curve radius m	Effort at WLL daN	Weight kg	Weight with locking device kg
HTP ATEX 500	*362504	500	A	50 - 220	25	0,9	-	8,0	14,5
HTP ATEX 1000	*362535	1.000	A	50 - 220	25	0,9	-	9,0	17,0
HTP ATEX 2000	*362542	2.000	A	66 - 220	25	1,15	-	16,0	24,0
HTP ATEX 500	*362559	500	B	160 - 300	40	0,9	-	10,6	17,1
HTP ATEX 1000	*362573	1.000	B	160 - 300	40	0,9	-	12,0	20,0
HTP ATEX 2000	*362580	2.000	B	160 - 300	40	1,15	-	19,3	27,3

### Technical data model HTG ATEX HIGH II 2 GD c IIC T4

Model	EAN-No. 403450934*	Capacity kg	Size	Beam flange width b mm	Beam flange thickness t mm	Min. curve radius m	Effort at WLL daN	Weight kg	Weight with locking device kg
HTP ATEX 500	*573894	500	A	50 - 220	25	0,9	-	8,0	14,5
HTP ATEX 1000	*573900	1.000	A	50 - 220	25	0,9	-	9,0	17,0
HTP ATEX 2000	*573917	2.000	A	66 - 220	25	1,15	-	16,0	24,0
HTP ATEX 500	*362764	500	B	160 - 300	40	0,9	-	10,6	17,1
HTP ATEX 1000	*362771	1.000	B	160 - 300	40	0,9	-	12,0	20,0
HTP ATEX 2000	*362788	2.000	B	160 - 300	40	1,15	-	19,3	27,3

**Technical data model HTG ATEX BASIC II 3 GD c IIB T4 / II 2 GD c IIA T4**

Model	EAN-No. 403550935*	Capacity kg	Size	Beam flange width b mm	Beam flange thickness t mm	Min. curve radius m	Effort at WLL daN	Weight*	Weight with locking device kg
HTP ATEX 500	*362597	500	A	50 - 220	25	0,9	3	9,7	16,2
HTP ATEX 1000	*362603	1.000	A	50 - 220	25	0,9	6	11,2	19,2
HTP ATEX 2000	*362610	2.000	A	66 - 220	25	1,15	7	18,0	26,0
HTP ATEX 3000	*362627	3.000	A	74 - 220	25	1,4	7	35,4	44,6
HTP ATEX 5000	*362634	5.000	A	90 - 220	25	1,8	9	51,8	62,3
HTP ATEX 500	*362641	500	B	160 - 300	40	0,9	3	12,6	19,1
HTP ATEX 1000	*362658	1.000	B	160 - 300	40	0,9	6	14,1	22,1
HTP ATEX 2000	*362665	2.000	B	160 - 300	40	1,15	7	21,3	29,3
HTP ATEX 3000	*362672	3.000	B	160 - 300	40	1,4	7	39,2	48,4
HTP ATEX 5000	*362689	5.000	B	180 - 300	40	1,8	9	56	66,5
HTG ATEX 8000	*362719	8.000	B	125 - 310	40	1,8	14	104,0	-
HTG ATEX 10000	*362726	10.000	B	125 - 310	40	1,8	14	104,0	-
HTG ATEX 15000	*377577	15.000	B	125 - 310	40	5,0	29	230,0	-
HTG ATEX 20000	*377584	20.000	B	125 - 310	40	5,0	29	230,0	-

**Technical data model HTG ATEX HIGH II 2 GD c IIC T4**

Model	EAN-No. 403550935*	Capacity kg	Size	Beam flange width b mm	Beam flange thickness t mm	Min. curve radius m	Effort at WLL daN	Weight*	Weight with locking device kg
HTP ATEX 500	*573948	500	A	50 - 220	25	0,9	3	9,7	16,2
HTP ATEX 1000	*573955	1.000	A	50 - 220	25	0,9	6	11,2	19,2
HTP ATEX 2000	*573962	2.000	A	66 - 220	25	1,15	7	18,0	26,0
HTP ATEX 3000	*573979	3.000	A	74 - 220	25	1,4	7	35,4	44,6
HTP ATEX 5000	*573986	5.000	A	90 - 220	25	1,8	9	51,8	62,3
HTP ATEX 500	*362825	500	B	160 - 300	40	0,9	3	12,6	19,1
HTP ATEX 1000	*362795	1.000	B	160 - 300	40	0,9	6	14,1	22,1
HTP ATEX 2000	*362801	2.000	B	160 - 300	40	1,15	7	21,3	29,3
HTP ATEX 3000	*377591	3.000	B	160 - 300	40	1,4	7	39,2	48,4
HTP ATEX 5000	*362818	5.000	B	180 - 300	40	1,8	9	56	66,5
HTG ATEX 8000	*573702	8.000	B	125 - 310	40	1,8	14	104,0	-
HTG ATEX 10000	*573719	10.000	B	125 - 310	40	1,8	14	104,0	-
HTG ATEX 15000	*573726	15.000	B	125 - 310	40	5,0	29	230,0	-
HTG ATEX 20000	*573733	20.000	B	125 - 310	40	5,0	29	230,0	-

\*Weight HTG without hand chain

**! Yale hoists and trolleys are not designed for passenger elevation applications and must not be used for this purpose.**

## Dimensions model HTP ATEX

Model	HTP ATEX 500 - A	HTP ATEX 1000 - A	HTP ATEX 2000 - A	HTP ATEX 3000 - A	HTP ATEX 5000 - A	HTP ATEX 500 - B	HTP ATEX 1000 - B	HTP ATEX 2000 - B	HTP ATEX 3000 - B	HTP ATEX 5000 - B
A, mm	77	82,5	98,5	114	132,5	92	97,5	113,5	129	147,5
D, mm	16	17	22	26	33	16	17	22	26	33
D1, mm	25	30	40	48	60	25	30	40	48	60
D2, mm	30	35	47	58	70	30	35	47	58	70
F1, mm	46	46	46	46	45,5	46	46	46	46	45,5
H1, mm	30,5	30,5	30,5	30	30	45,5	45,5	45,5	45	45
I (HTP), mm	71,5	71,5	95,5	131	142,5	71,5	71,5	95,5	131	142,5
L, mm	260	260	310	390	450	260	260	310	390	450
L1, mm	130	130	150	180	209	130	130	150	180	209
O, mm	60	60	80	112	125	60	60	80	112	125
P1, mm	168	168	168	168	168	168	168	168	168	168
P2, mm	146	150	155	160	167,5	146	150	155	160	167,5
L3, mm	346	346	396	476	556	346	346	396	476	556

## Dimensions model HTG ATEX

Model	HTG ATEX 500 - A	HTG ATEX 1000 - A	HTG ATEX 2000 - A	HTG ATEX 3000 - A	HTG ATEX 5000 - A	HTG ATEX 500 - B	HTG ATEX 1000 - B	HTG ATEX 2000 - B	HTG ATEX 3000 - B	HTG ATEX 5000 - B	HTG ATEX 8000 - B	HTG ATEX 10000 - B	HTG ATEX 15000 - B	HTG ATEX 20000 - B
A, mm	77	82,5	98,5	114	132,5	92	97,5	113,5	129	147,5	276	276	270	270
B, mm	-	-	-	-	-	-	-	-	-	-	52	52	70	70
D, mm	16	17	22	26	33	16	17	22	26	33	30	30	35	35
D1, mm	25	30	40	48	60	25	30	40	48	60	80	80	110	110
D2, mm	30	35	47	58	70	30	35	47	58	70	114	114	155	155
F (HTG), mm	91,5	91,5	90,5	107,5	149,5	91,5	91,5	90,5	107,5	149,5	113	113	113	113
F1, mm	46	46	46	46	45,5	46	46	46	46	45,5	77	77	-	-
H1, mm	30,5	30,5	30,5	30	30	45,5	45,5	45,5	45	45	45	45	45	45
I (HTG), mm	76,5	76,5	98	132,5	148,5	76,5	76,5	98	132,5	148,5	170	170	170	170
L, mm	260	260	310	390	450	260	260	310	390	450	430	430	870	870
L1, mm	130	130	150	180	209	130	130	150	180	209	200	200	200	200
L2, mm	-	-	-	-	-	-	-	-	-	-	-	-	115	115
O, mm	60	60	80	112	125	60	60	80	112	125	150	150	150	150
P (HTG), mm	110	110	110	110	110	110	110	110	110	110	163	163	163	163
P1, mm	168	168	168	168	168	168	168	168	168	168	193	193	-	-
P2, mm	146	150	155	160	167,5	187	187	189,5	191,5	191,5	-	-	-	-
T, mm	-	-	-	-	-	-	-	-	-	-	270	270	270	270
L3, mm	346	346	396	476	556	346	346	396	476	556	536	536	976	976
P3, mm	194	194	194	195	195	194	194	195	195	195	-	-	-	-

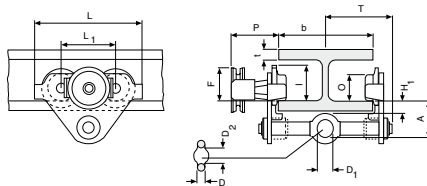

Model HTP/HTG ATEX, 500 - 5000 kg

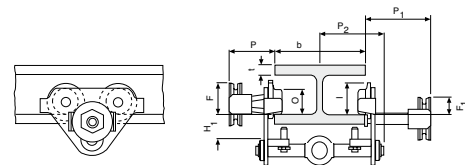

Model HTP/G ATEX with locking device, 500 - 5000 kg

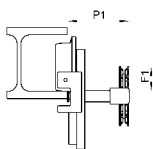

Model/HTG ATEX 10.000 kg locking device

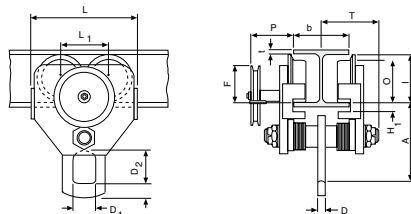

Model HTG ATEX, 10000 kg

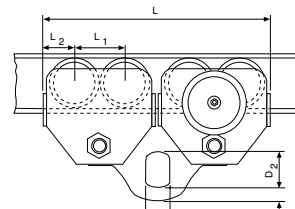

Model HTG ATEX, 20000 kg

## Ratchet lever hoist model UNOplus ATEX

Capacity 750 - 6.000 kg

Further technical development turns the ratchet lever hoist into the successor of our proven UNO model. The versatile tool for lifting, pulling and securing of loads is characterised by its compact design and robust stamped steel construction.

### Features

- Due to optimized gearing and improved bearings in the housing cover a minimum effort is required to operate the short hand lever.
- Steel hand wheel as standard.
- Automatic screw-and-disc type load brake with corrosion protected components.
- Standard free chaining device to quickly attach the load or to pull the chain through the hoist in both directions.
- Robust chain guide rollers eliminate fouling and jamming of chain on the load sheave.
- Sturdy bottom block with encapsulated bolt connections.
- Alloyed steel link chain in accordance with national and international standards and regulations.
- Drop forged suspension and load hooks are made from non-aging, high tensile steel and fitted with robust safety latches.



**Yale hoists and trolleys are not designed for passenger elevation applications and must not be used for this purpose.**

### Technical data model UNOplus ATEX

Model	EAN-No. 4025092*	Capacity in kg/ number of chain falls	Chain dimensions d x p mm	Load chain grade mm	Lift with one full lever turn mm	Handle pull at WLL daN	Weight at standard lift (1,5 m) kg
UNOplus ATEX 750	*336536	750/1	6 x 18	T	20	20	7,2
UNOplus ATEX 1500	*336543	1.500/1	8 x 24	T	22	35	12,5
UNOplus ATEX 3000	*336550	3.000/1	10 x 30	T	17	40	21,5
UNOplus ATEX 6000	*336567	6.000/2	10 x 30	T	9	40	32,0

### Dimensions model UNOplus ATEX

Model	UNOplus ATEX 750	UNOplus ATEX 1500	UNOplus ATEX 3000	UNOplus ATEX 6000
Amin., mm	340	410	510	690
B, mm	22	28	36	45
C, mm	26	32	40	44
D, mm	16	21	27	33
E, mm	250	330	380	380
F, mm	150	170	220	220
G, mm	70	80	100	100
H, mm	80	90	120	120
J, mm	150	180	210	210
K, mm	60	80	90	90
L, mm	90	100	120	120

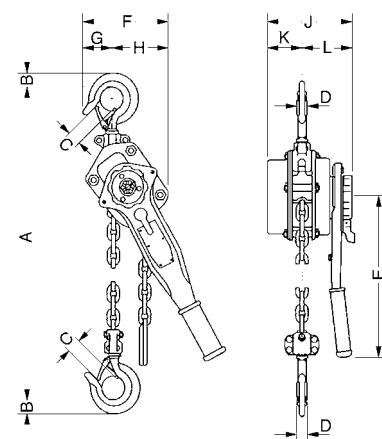



## Electric wire rope winch model BETA-EX

Lifting capacity 320 - 7.500 daN

Wire rope winches of the series BETA-EX are designed according to the EU Directives 94/9/EG and MRL 2006/42/EG. The models are usable in any place, where the risk of ignition of explosive atmosphere exists. (Mixture of air, gases, fumes and dust/air-mixture, respective-ly). Due to a specially-tailored modular system, the suitable winch for each individual application can be put together easily. The BETA-EX is characterized by the excellent workmanship in connection with the reliable and stable gear motors.

### Features

- Electric control incorporated in a flame-proof housing Ex II 2 GD de IIB T4 T 135° C
- Electric control not ATEX-compliant (Mounting outside of ATEX-area)
- Hand-actuated auxiliary switch in ATEX-design with Up/Down and emergency stop for an enhanced operating safety.
- From a load capacity of 1000 kg equipped as standard with an overload protection.
- Standard operating voltage: 380 - 420 V, 3-phases, 50 Hz - Euro-voltage
- Insulation class F
- Grooved drum and one rope fixation on each flanged wheel.
- Suitable ambient temperature: -20° C to +40° C.

### Application area

Chemical or petrochemical industry, biogas plants, paint shops

### Option

- Different ambient temperatures
- Different operating voltages
- Electric overload protection for winches with a load capacity below 1000 kg
- Infinitely variable speed regulation
- Rope pressure drum
- Slack rope switch
- Gear limit switch
- Special surface coating
- Multi compartment drum or drum extensions for a higher rope capacity.
- Sheaves, pulley blocks (ATEX-compliant Ex II 2 GD IIB T4 135° C IP 6 5).
- Special wire ropes for ATEX-areas with copper-plated load hook.

**For determining the required rope length, please take into account that at least 2 to 3 windings must remain on the drum!**

## Technical data model BETA-EX

Art.-No.	Size	Capacity	Capacity	Lifting	Lifting	Rope	Motor	Classification	Useable	Useable	Weight
		1 <sup>st</sup> layer	top layer	speed	speed	diameter*	kW		rope length	rope length	
		kg	kg	m/min	m/min	mm		FEM/ISO	m	m	kg
040039001	P1	kg	272	5,9	7,0	5	0,37	2 m/M5	16,2	77,8	82,4
040039003	P1	320	272	13,8	16,4	5	0,75	2 m/ M5	16,2	77,8	89,9
040039004	P1	320	272	19,0	22,6	5	1,1	2 m/ M5	16,2	77,8	106
040039020	P1,5	500	412	6,0	7,5	6	0,55	2 m/ M5	13,62	67,58	95,9
040039021	P1,5	500	412	13,1	16,4	6	1,1	2 m/ M5	13,62	67,58	113
040039023	C1,5	630	492	6,8	8,7	6	0,75	1 Am/M4	10,76	54,76	95,9
040039024	C1,5	630	492	14,4	18,4	6	1,5	1 Am/ M4	10,76	54,76	113
040039031	P2	800	669	4,7	5,6	8	0,75	2 m/ M5	17,1	85,5	125,9
040039033	P2	800	669	11,4	13,7	8	1,5	2 m/ M5	17,1	85,5	151,5
040039034	P2	800	669	20,5	24,6	8	3	2 m/ M5	17,1	85,5	151,5
040039037	C2	980	711	3,4	4,7	9	0,55	1 Am/ M4	11	77,4	125,9
040039038	C2	980	711	6,7	9,2	9	1,1	1 Am/ M4	11	77,4	143
040039039	C2	980	711	16,6	22,9	9	3	1 Am/ M4	11	77,4	151,5
040039050	P3	1.250	1.077	5,2	6,0	12	1,1	2 m/ M5	16,3	61,3	203,5
040039051	P3	1.250	1.077	10,4	12,1	12	2,2	2 m/ M5	16,3	61,3	215
040039052	P3	1.250	1.077	13,8	16,0	12	3	2 m/ M5	16,3	61,3	215
040039055	C3	1.600	1.166	3,9	5,4	12	1,1	1 Am/ M4	12,1	87,7	203,5
040039057	C3	1.600	1.166	10,3	14,1	12	3	1 Am/ M4	12,1	87,7	215
040039058	C3	1.600	1.166	19,2	26,3	12	5,5	1 Am/ M4	12,1	87,7	287,4
040039059	E3	2.000	1.299	3,1	4,8	12	1,1	1 Bm/ M3	9,7	73,7	203,5
040039060	E3	2.000	1.299	8,3	12,8	12	3	1 Bm/ M3	9,7	73,7	215
040039061	E3	2.000	1.299	15,5	24,5	12	5,5	1 Bm/ M3	9,7	73,7	287,4
040039065	P3,5	2.500	2.083	4,9	5,9	14	2,2	2 m/ M5	13,8	53,9	262
040039067	P3,5	2.500	2.083	9,3	11,2	14	4	2 m/ M5	13,8	53,9	301,6
040039068	P3,5	2.500	2.083	12,9	15,5	14	5,5	2 m/ M5	13,8	53,9	338,4
040039070	C3,5	3.200	2.169	4,0	5,9	14	2,2	1 Am/ M4	11,4	85,6	262
040039072	C3,5	3.200	2.169	7,6	11,3	14	4	1 Am/ M4	11,4	85,6	301,6
040039073	C3,5	3.200	2.169	10,6	15,7	14	5,5	1 Am/ M4	11,4	85,6	338,4
040039081	C4	4.000	2.664	5,7	8,6	18	4	1 Am/ M4	12,7	98,3	502,6
040039082	C4	4.000	2.664	10,4	15,7	18	7,5	1 Am/ M4	12,7	98,3	539,4
040039083	C4	4.000	2.664	15,5	23,3	18	11	1 Am/ M4	12,7	98,3	617,5
040039085	E4	5.000	3.298	4,7	7,2	16	4	1 Bm/ M3	11,9	91,5	502,6
040039086	E4	5.000	3.298	8,6	13,1	16	7,5	1 Bm/ M3	11,9	91,5	539,4
040039087	E4	5.000	3.298	12,7	19,3	16	11	1 Bm/ M3	11,9	91,5	617,5
040039094	C5	6.300	4.395	2,9	4,2	20	3	1 Am/ M4	16,4	123,5	1.047,4
040039095	C5	6.300	4.395	6,5	9,3	20	7,5	1 Am/ M4	16,4	123,5	1.111,4
040039096	C5	6.300	4.395	9,6	13,7	20	11	1 Am/ M4	16,4	123,5	1.205,5
040039097	E5	7.500	4.891	2,3	3,6	20	3	1 Bm/ M3	13,4	104,8	1.047,4
040039098	E5	7.500	4.891	5,3	8,1	20	5,5	1 Bm/ M3	13,4	104,8	1.111,4
040039099	E5	7.500	4.891	7,8	11,9	20	11	1 Bm/ M3	13,4	104,8	1.205,5

\* recommended rope 1960 N/mm<sup>2</sup> (not included in the delivery package)

**Pfaff winches are not designed for passenger elevation applications and must not be used for this purpose.**

**Dimensions model BETA-EX**

Art.-No.	040039001	040039003	040039004	040039020	040039021	040039023	040039024	040039031	040039033	040039034
A, mm	215	215	215	215	215	215	215	270	270	270
B, mm	300	300	300	300	300	300	300	400	400	400
Ø C, mm	13,5	13,5	13,5	13,5	13,5	13,5	13,5	18	18	18
D, mm	6	6	6	6	6	6	6	8	8	8
F, mm	805	874	944	888	958	888	958	987	1.089	1.089
G, mm	340	340	340	340	340	340	340	465	465	465
H, mm	320	320	320	370	370	370	370	472	472	472
H1, mm	150	150	150	150	150	150	150	205	205	205
L, mm	200	200	200	200	200	200	200	250	250	250
Ø M, mm	175	175	175	175	175	138	138	242	242	242

Art.-No.	040039037	040039038	040039039	040039050	040039051	040039052	040039055	040039057	040039058	040039059
A, mm	270	270	270	320	320	320	320	320	320	320
B, mm	400	400	400	510	510	510	510	510	510	510
Ø C, mm	18	18	18	22	22	22	22	22	22	22
D, mm	8	8	8	10	10	10	10	10	10	10
F, mm	987	1.057	1.089	1.160	1.192	1.192	1.160	1.192	1.330	1.160
G, mm	465	465	465	570	570	570	570	570	570	570
H, mm	472	472	472	598	598	598	598	598	598	598
H1, mm	205	205	205	260	260	260	260	260	260	260
L, mm	250	250	250	300	300	300	300	300	300	300
Ø M, mm	175	175	175	295	295	295	218	218	218	175

Art.-No.	040039060	040039061	040039065	040039067	040039068	040039070	040039072	040039073	040039081	040039082
A, mm	320	320	320	320	320	320	320	320	380	380
B, mm	510	510	510	510	510	510	510	510	510	660
Ø C, mm	22	22	22	22	22	22	22	22	26	26
D, mm	10	10	10	10	10	10	10	10	12	12
F, mm	1.192	1.330	1.204	1.280	1.341	1.204	1.280	1.341	1.418	1.553
G, mm	570	570	570	570	570	570	570	570	720	720
H, mm	598	598	672	672	672	672	672	672	816	816
H1, mm	260	260	260	260	260	260	260	260	325	325
L, mm	300	300	300	300	300	300	300	300	350	350
Ø M, mm	175	175	295	295	295	242	242	242	295	295

Art.-No.	040039083	040039085	040039086	040039087	040039094	040039095	040039096	040039097	040039098	040039099
A, mm	380	380	380	380	430	430	430	430	430	430
B, mm	660	660	660	660	800	800	800	800	800	800
Ø C, mm	26	26	26	26	34	34	34	34	34	34
D, mm	12	12	12	12	15	15	15	15	15	15
F, mm	1.667	1.418	1.553	1.667	1.752	1.638	1.822	1.752	1.638	1.822
G, mm	720	720	720	720	882	882	882	882	882	882
H, mm	816	816	816	816	1.060	1.060	1.060	1.060	1.060	1.060
H1, mm	325	325	325	325	400	400	400	400	400	400
L, mm	350	350	350	350	400	400	400	400	400	400
Ø M, mm	295	242	242	242	364	364	364	295	295	295

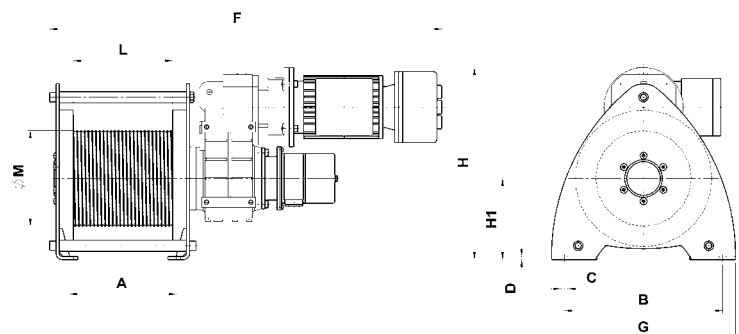



**Sheave block-EX  
for rope guidance,  
equipped with ball bearings,  
incl. earthing screw and copper-coated sheave  
model DSRBX S**

Technical data model DSRBX S

Model	Art.-No.	Classification  FEM/ISO	Pulling force	Pulling force	Rope diameter  mm
			in kg at deflection 90°	in kg at deflection 180°	
DSRBX S 90/4	0400431113	2m/M5	700	500	4
DSRBX S 145/5	0400431114	4m/M6	1.100	800	5
DSRBX S 145/6	0400431115	2m/ M5	1.100	800	6
DSRBX S 185/8	0400431117	2m/ M5	2.300	1.630	8
DSRBX S 185/9	0400431118	1Am/ M4	2.300	1.630	9
DSRBX S 270/12	0400431121	2m/ M5	2.500	1.800	12
DSRBX S 325/14	0400431123	2m/ M5	4.500	3.200	14
DSRBX S 400/16	0400431124	3m/ M6	5.000	3.800	16
DSRBX S 400/18	0400431125	2m/ M5	5.000	3.800	18
DSRBX S 490/20	0400431126	3m/ M6	8.000	6.000	20



Dimensions model DSRBX S

Model	DSRBX S 90/4	DSRBX S 145/5	DSRBX S 145/6	DSRBX S 185/8	DSRBX S 185/9	DSRBX S 270/12	DSRBX S 325/14	DSRBX S 400/16	DSRBX S 400/18	DSRBX S 490/20
Art.-No.	0400431113	0400431114	0400431115	0400431117	0400431118	0400431121	0400431123	0400431124	0400431125	0400431126
B, mm	85	125	125	138	138	191	260	302	302	313
C, mm	90	160	160	195	195	290	350	430	430	580
Ø D, mm	90	145	145	185	185	270	325	400	400	490
Ø D1, mm	20	25	25	30	30	40	50	50	50	65
Ø Dm, mm	80	125	125	160	162	246	297	368	364	450
E, mm	62	88	88	106	106	138	180	212	212	220
H, mm	134	224	224	273	273	407	490	612	612	694
K, mm	65	110	110	135	135	202	242	310	310	340
L, mm	120	200	200	245	245	360	440	530	530	650
Ø M/M1, mm	9/9	11,5/13	11,5/13	13,5/15	13,5/15	18/20	22/25	26/30	26/30	34/40
S, mm	4	6	6	8	8	10	12	15	15	16

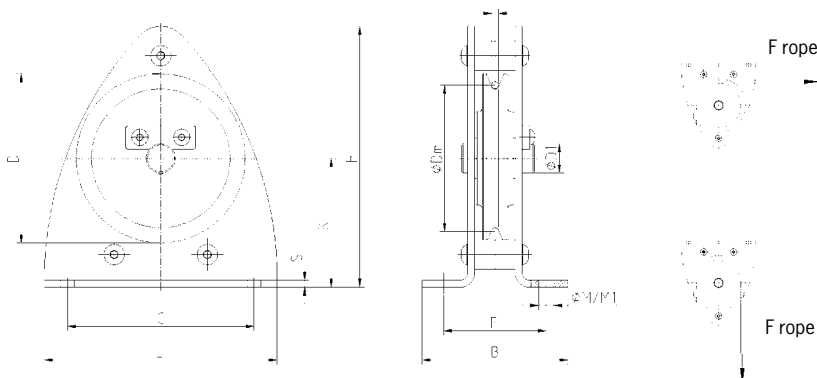



## Hand winch with load pressure brake model OMEGA-EX

Lifting capacity 630 and 1.000 daN

The hand winch OMEGA Ex is a complete new construction and was developed especially for the high safety requirements in potentially explosive atmospheres.

All components of the OMEGA-Ex are designed to avoid effectively an inadmissible heating of the surfaces.

Carefully selected materials and the sophisticated construction of the winch prevent the occurrence of mechanically caused sparks, for example by intrusion of foreign materials.

### Features

- Winch housing made of aluminum permanent mold casting for a low own weight, rope drum made of steel, chemically nickel-plated for a high versatility.
- Integrated load pressure brake.
- Closed gear with oil bath lubrication. The large oil volume ensures a high cooling effect.
- Equipotential bonding to avoid electrostatic charging.
- Pivotal crank handle.
- Suitable for ambient temperatures of -20° C to +40° C.

### Application area

Chemical or petrochemical industry, biogas plants, paint shops

### Technical data model OMEGA-EX

Model	Art.-No.	Capacity 1st layer daN	Capacity top layer daN	Rope diameter mm	Lift per crank rotation mm	Required crank effort daN	Weight without rope kg
OMEGA-EX 6	040022319	630	305	7	21	10	22
OMEGA-EX 10	040029019	1.000	500	8	22	16	22

\* Gem. DIN 3060 FE-znk 1770sZ-spa

### Dimensions model OMEGA-EX

Model	040039001	040039003
A, mm	345	345
B, mm	297	297
C, mm	107	107
D, mm	65	65
E, mm	156	156
F, mm	345	345
G, mm	70	70
H, mm	95	95
I, mm	123	123
J, mm	250	250
Ø K mm	26	26
L, mm	107	107
M, mm	82	82
N, mm	88	88
O, mm	310,5	310,5
P, mm	56	56
Q, mm	56	56
R, mm	117,6	117,6
Ø S mm	72	72
T, mm	200	200

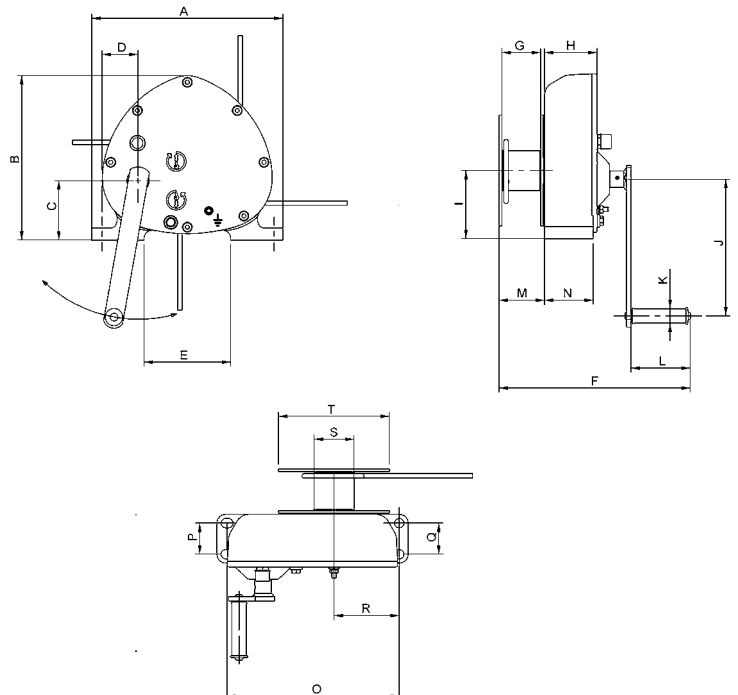

## Rack and pinion jack model ZWW-EX

Capacity 250 kg

The rack and pinion jack is suitable for lifting, lowering, pulling and pushing, for horizontal displacement, supporting, adjusting or fixing of heavy components or whole appliances and equipment in hazardous areas.

### Features

- Carefully selected materials and a high-grade coating prevent the occurrence of mechanically caused sparks.
- No inadmissible heating of the surfaces due to the intelligent design of the individual parts.
- Equipotential bonding and limited surface area to avoid electrostatic charging.
- The grease-lubricated, self-locking worm gear is set into operation by rotations on the crank. It provides not only for easy movement of the load, but also for a reliable safety in every position.

### Application area

Plant construction, shipping, wastewater treatment plants, chemical industry and food industry.



### Technical data model ZWW-EX

Model	Art.-No.	Capacity kg	Rack length mm	Lift mm	Weight kg
ZWW-EX	040052648	250	735	530	5,7

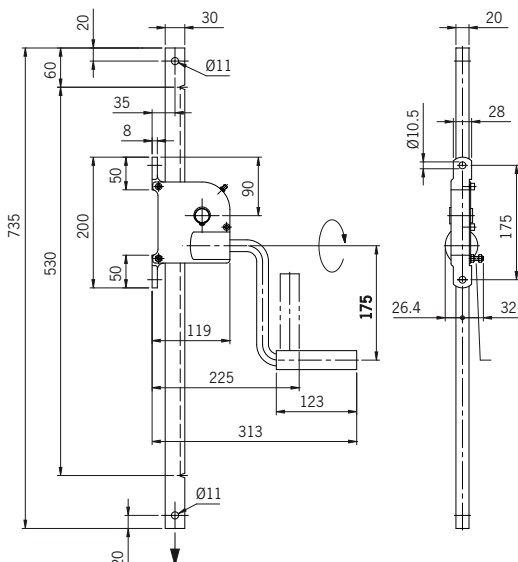



## Hand pallet truck, stainless steel version model HU 20-115 VATP ATEX PROLINE

Capacity 2.000 kg

The hand pallet truck is designed for the use in explosive environments (zone 1 and 2) and is classified acc. to ATEX II 2 GD c IIC T4.

### Features

- Ergonomic safety control handle for one-hand operation of lifting, driving and lowering.
- Low maintenance high performance hydraulic pump with hard chromium plated piston and pressure relief valve. Hydraulic unit made of V4A-316 stainless steel.
- Frame, adjustable connecting rods, bolts and the torsion tube are made of high quality V4A-316 stainless steel.
- Steering angle of 105 degree to each side for easy handling in confined spaces.
- Conductive steering rollers (antistatic).

**Before the use in explosive environments the operator has to create an explosion protection document acc. to the machinery directive**

● **1999/92/EG!**

### Technical data HU 20-115 VATP ATEX PL

Model	HU 20-115 VATP ATEX PL
Art.-No.	040054147
Capacity, kg	2.000
Weight, kg	86
Tyre type*	PA/VG
Steering rollers, mm	200 x 50
Load rollers, mm	82 x 70
Stroke h3, mm	115
Height of control handle h14, mm	1.200
Fork height lowered h13, mm	85
Fork width e, mm	160
Fork length l, mm	1.150
Outside dimension of forks b1, mm	540

\*PA ... Polyamide, VG ... Solid rubber

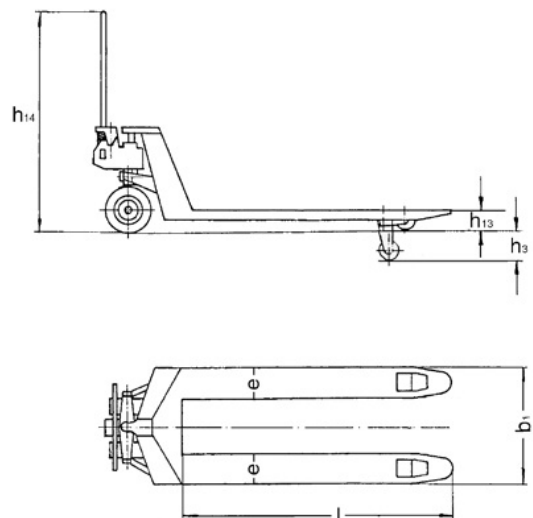

## Checklist

Pfaff-silberblau develops, produces and sets up system solutions and complete actuator units according to individual customer requirements for different applications: product technique, transport technique, foundry technique, mining, hydraulic engineering, shipbuilding, research, building service, etc.

Of course, also available in accordance with regulation 94/9/EG (ATEX) for the use in areas with an explosion hazard.

Simply ask for our checklist for screw jacks and linear drives!

### 2.5 Type of protection

for non-electrical equipment for use in potentially explosive areas:

EN 13463-2-1	Protection by flameproof enclosure „dR“
EN 13463-3	Protection by flameproof enclosure „dP“
EN 13463-4	Protection by inherent safety „dI“
EN 13463-5	Protection by constructional safety „dC“
EN 13463-6	Protection by control of ignition sources „dS“
EN 13463-7	Protection by pressurization „dP“
EN 13463-8	Protection by liquid immersion „dL“

- Pfaff-silberblau drive elements are designed in accordance with type of protection „dC - Protection by constructional safety“.
- Drive elements produced for use in Zones 1 and 2 (gas) are designed in accordance with type of protection „dL - Protection by liquid immersion“ (drive elements with oil lubrication).
- Type of protection „dS - Protection by control of ignition source“ can be provided by means of control of motor performance.

### 3 Which certification or check is required for which zone?

Directive 94/9/EC Chapter II Item 8 and Appendix VII

Category	1	2	21	22
Explosive atmosphere*	G	D	D	D
Motor	EC type examination certificate from a nominated office	EC type examination certificate from a nominated office	Internal process control by manufacturer (Directive 94/9/EC Appendix VII)	Declaration of conformity from the manufacturer
Drive	Internal process control by manufacturer (Directive 94/9/EC Appendix VII)	Declaration of conformity from the manufacturer and filing of the explosion prevention documentation with a nominated office	Internal process control by manufacturer (Directive 94/9/EC Appendix VII)	Declaration of conformity from the manufacturer

\*G = Gas / D = Dust

### 4 Hazard analysis according to DIN EN 1127

The purpose of the hazard analysis is to establish which risks of ignition apply to Pfaff-silberblau drive elements and the safety precautions to be taken to provide the level of safety required.

Risk of ignition from:

- Hot surface
- Mechanically generated sparks caused by friction, impact and degradation
- Electrostatic charging
- Chemical reaction
- Improper assembly/installation

### 5 Documentation for securing protection against explosion

- Checklist for provision of all data of relevance to explosion protection.
- Questionnaire for the specification of technical data.
- Written order contract for the design of the drive elements.
- Documented calculations for the specification of the thermal limits and the life of the bearings.
- Production checklist for testing the components: Sealing faces, roughness of the spindle and bearing nuts, bearing face of the gearing.
- Operating manual with 94/9/EC declaration of conformity.
- Rating plate.

### 5.1 Identifying markings

Ex II 2 G/D ck T4/100°C

Ex-marking \_\_\_\_\_  
 Device group \_\_\_\_\_  
 Category \_\_\_\_\_  
 Ex atmosphere \_\_\_\_\_  
 Type of protection \_\_\_\_\_  
 Temperature class \_\_\_\_\_  
 Max. surface temperature on which 5 mm of dust can settle \_\_\_\_\_

### 2.3 Zoning

Zones in potentially explosive atmospheres

Zone	Gas	Dust	Probability of occurrence of a potentially explosive atmosphere
0	20		Permanent, long-term, frequent (prevailing situation)
1	21		Occasional, during normal operations
2	22		Seldom, temporary

### 2.4 Temperature classes and explosion groups

Temperature class	Max. surface temperature of the equipment [°C]	Ignition temperature of the combustible substances [°C]	Explosion group		
			II A	II B	II C
T1	450	> 450	Ammonia, acetone-benzene, ethane, ethyl acetate, carbon monoxide, methane, methanol, methyl benzene, propane	Carbon over gas, water gas (enriched)	Hydrogen
T2	300	> 300... < 450	n-butane, n-butanol, cyclohexanone, acetic anhydride, natural gas, liquid gas	Butadiene 1,3, ethanol, ethylene, ethylene oxide	Acetylene
T3	200	> 200... < 300	Petrol, diesel, heating oil, aircraft fuel, n-hexane	Cuide oil, isoprene, hydrogen sulphide	
T4	135	> 135... < 200	Acetaldehyde ether	Ethyl ether	
T5	100	> 100... < 135			
T6	85	> 85... < 100			Carbon bisulphide

Pfaff-silberblau drive elements are designed on the basis of an a & housing temperature of 80 °C, such that if the room temperature is 40 °C the surface temperature will be 120 °C. This results in a safety factor of 1.12 relative to the max. surface temperature of 135 °C.

For explosion proofing in respect of dust, the operator is required to provide information on the maximum ignition temperature of the air/dust mixture.

### Questionnaire - Page 1

Pfaff-silberblau Hebezeugfabrik GmbH  
 Am Silberpark 2-8, 86438 Kissing  
 Phone +49 / 83 33 / 21 21-800, Fax +49 / 83 33 / 21 21-805  
 E-Mail: antriebstechnik@pfaff-silberblau.com, Internet: www.pfaff-silberblau.com

### 5.2 CHECKLIST for explosion protection data

To enable Pfaff-silberblau lifting units/drive elements to be designed in accordance with EC directive 94/9/EC it is imperative that this checklist is completed and all outstanding questions regarding explosion protection be answered conscientiously.

Firm: \_\_\_\_\_  
 Address: \_\_\_\_\_  
 Department: \_\_\_\_\_ Phone: \_\_\_\_\_  
 Fax: \_\_\_\_\_ E-mail: \_\_\_\_\_  
 Name: \_\_\_\_\_

### Device group, device category and zone allocation (see Item 2.1)

Device group	Please enter a cross
Device group I	Not available
Device group II	X

Category / Zone	Ex-atmosphere...	Please enter a cross
Category 1 (in Zone 0/20)	...is the permanent, long-term or frequent situation.	Not available
Category 2 (in Zone 1/21)	...is an occasional occurrence.	
Category 3 (in Zone 2/22)	...is a rare occurrence and then only temporarily.	

### Temperature classes and explosion groups (see Item 2.4)

Temp. class	Max. surface temperature of the equipment [°C]	Ignition temperature of the combustible substances [°C]	Please enter a cross
T1	> 450	> 450	
T2	> 300... < 450	> 300... < 450	
T3	> 200... < 300	> 200... < 300	
T4	> 135... < 200	> 135... < 200	

### PFaff silberblau Checklist



Worm gear screw jacks/  
 Linear Drives  
 according to 94/9/EC (ATEX)  
 for use in potentially explosive areas

**Ex**

Safety - Made by Pfaff-silberblau

# Columbus McKinnon Hungary Kft.

## Technical questionnaire

To enable us to design lifting units/drive elements in accordance with EU-directive 94/9/EG it is essential that this checklist is completed and all open questions regarding explosion protection are answered carefully.

### Equipment group, categories and zones

Equipment group I	
(only for mining fire damp protection)	
	Category M1
	Category M2

Equipment group II		
	Category - Zone	Ex-atmosphere ...
—	Category 1 - Zone 0/20	... is present continuously for long periods or frequently (not available)
	Category 2 - Zone 1/21	... is present occasionally in normal operation
	Category 3 - Zone 2/22	... is unlikely to be present except for a short period of time.

### Ex-atmosphere

Medium? If dusts are involved - please specify

Surrounding temperature (only permissible between -20 up to +40°C)

Zone			
	Gases/Vapours G		Dust D
—	0	—	20
	1		21
	2		22

Explosion group	
	IIA
	IIB
	IIC



### Temperature classes

	Temperature class	Max. surface temperature of the equipment [° C]	Max. ignition temperature of combustible substances [° C]	Max. surface temperature for dust [° C]
	T1	450	> 450	Ignition temperature ..... Smouldering temperature .....
	T2	300	> 300... < 450	
	T3	200	> 200... < 300	
	T4	135	> 135... < 200	
—	T5	100	> 100... < 135	
—	T6	85	> 85... < 100	

T1 up to T4 available, T5 and T6 not available

Place, Date \_\_\_\_\_

Signature \_\_\_\_\_

## You would like to know more?

Simply ask for our product catalogue.

Of course, we can also contact you personally.

*Simply fill in ...*

Company: \_\_\_\_\_

Phone: \_\_\_\_\_

Name: \_\_\_\_\_

Fax: \_\_\_\_\_

Street: \_\_\_\_\_

e-mail: \_\_\_\_\_

Zip code: \_\_\_\_\_

Place: \_\_\_\_\_

Country: \_\_\_\_\_

*... select ...*

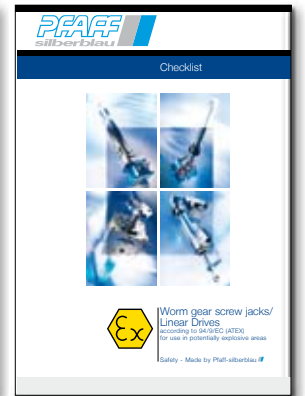

**Yes,**  we would like to know more about the product portfolio “lift & shift”.  
Please send your product catalogue.

**Yes,**  we would like to know more about the product portfolio “screw jacks”.  
Please send your product catalogue.

**Yes,**  we would like a non-binding consultation, resp. do have a specific requirement for screw jacks acc. to regulation 94/9/EG (ATEX) for the use in areas with an explosion hazard.

**Yes,**  we would like a non-binding consultation, resp. do have a specific requirement. Please contact us.

*... and fax to us!*

to our fax number **+36 22 880 503**  
or send us an e-mail to **info@cmco-hungary.com**



Place, Date \_\_\_\_\_

Signature \_\_\_\_\_



**COLUMBUS McKINNON Hungary Kft.**

**Vásárhelyi út 5., H-8000 Székesfehérvár**

Tel: +36 22 880 540

Fax: +36 22 880 503

**Bogáncs utca 4., H-1151 Budapest**

Tel: +36 1 308 1262

Fax: +36 1 307 7497

**Kiss Ernő utca 23., H-3531 Miskolc**

Tel: +36 70 314 3407

Fax: +36 22 880 503

**[info@cmco-hungary.com](mailto:info@cmco-hungary.com) - [www.cmco-hungary.com](http://www.cmco-hungary.com)**

We reserve the right to change product specifications without prior warning.

We accept no responsibility for printing or typing errors.

Reproduction or reprinting of this brochure only with written permission.